

Emergency Back-up Power Generation for Water & Wastewater Facilities

Lance Dubea

Advanced Power Technologies, Inc

Emergency Back-up power sources

- Multiple utility feeds
- On site emergency power sources
 - Diesel powered generator sets
 - Natural Gas generator sets
 - Bi-fuel generator sets
 - Gas Turbines

Multiple Utility Feeds

- Pros
 - Majority of the equipment is owned and maintained by the utility company.
 - Lowest cost per kWh produced during outage of the primary feed.
- Cons
 - Susceptibility to failure during natural disaster higher due to failure upstream.

Multiple Utility Feeds

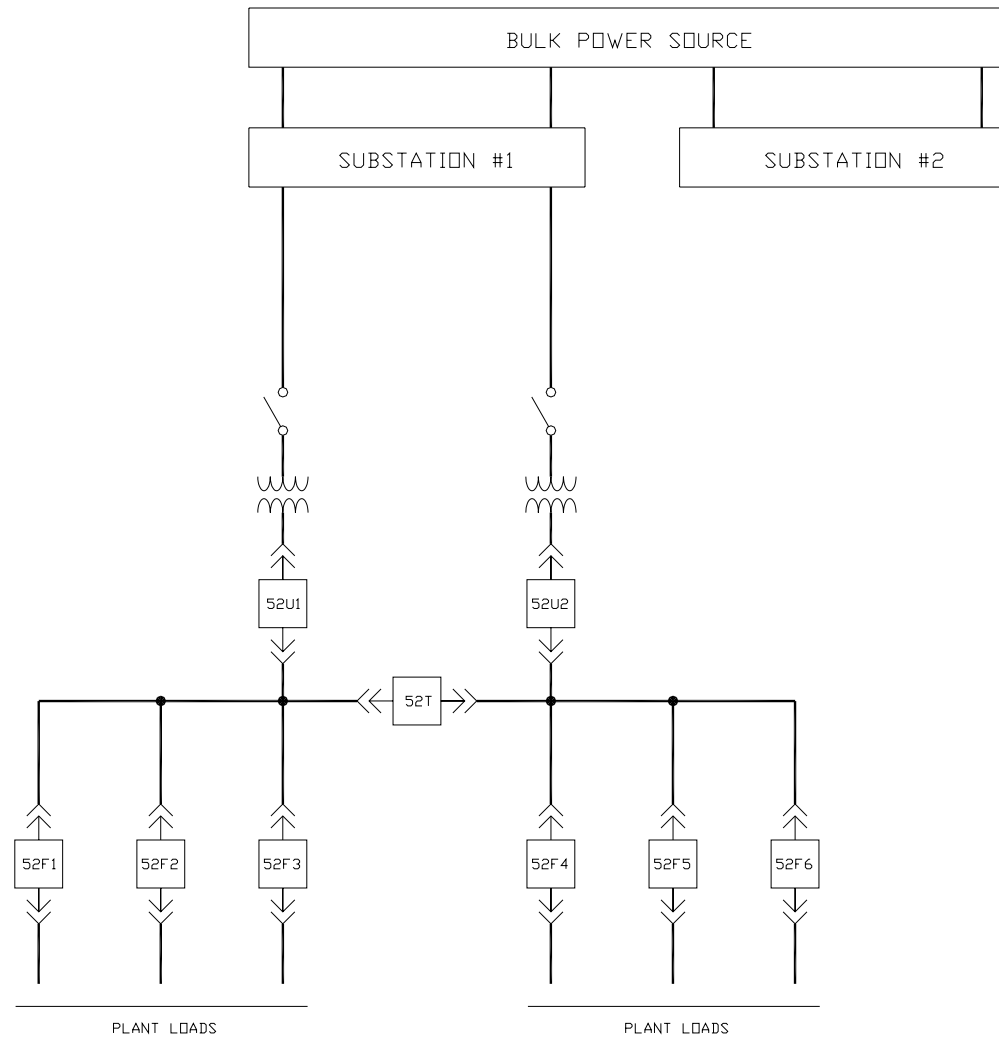

Diesel Powered Generator Sets

- Pros
 - Reliable technology
 - High power density
 - On site fuel storage
 - Cost per kW installed
- Cons
 - High cost of fuel per kWh produced
 - Emissions

Natural Gas Powered Generator Sets

- Pros
 - Low cost of fuel per kWh produced
 - Emissions
- Cons
 - Less reliable source of fuel during natural disasters
 - Inferior transient response
 - Cost per kW installed

Bi-fuel Powered Generator Sets

70% Diesel 30% Natural Gas

- Pros
 - Lower installation cost per kW than Natural gas engine or Turbine
 - Ability to supplement diesel fuel with natural gas during power outage, if natural gas supply remains available
- Cons
 - Higher installation cost than diesel genset
 - Not commonly offered by major engine manufacturers
 - Additional complexity

Natural Gas Turbines

- Pros
 - High power density
 - Better transient response than Natural gas engines
- Cons
 - Less reliable source of fuel during natural disasters
 - Higher cost per kW installed
 - Power output is temperature dependent

Power Source Summary

	Diesel	Nat. Gas	Bi-fuel	Gas Turbines
Power Density	***	*	**	****
Emissions	*	****	**	***
Installed cost	****	**	***	*
Fuel cost	*	****	**	***
Transient response	***	*	***	****

Power System Design Considerations

- Small power systems (<1000kW)
 - Typically 480 Volts
 - One generator set
 - Automatic Transfer Switch
 - Automatic Transfer Switchboard
- Large power systems
 - Typically 4.16 kV or 12.47 kV
 - Automatic Transfer Switchgear
 - Single or Multiple generator sets
 - Utility Paralleling Switchgear

Power System Design Considerations

- Neutral grounding
 - Solid grounded
 - Most common in 480 V systems
 - Low impedance grounded
 - Most common in medium voltage systems
 - High impedance grounded
 - Less common
 - More complex to design
 - Generally provides higher reliability of service

Contactor Based ATS

- Readily Available
- Inexpensive
- Open Transition
- Requires external protection
 - circuit breakers
 - fuses

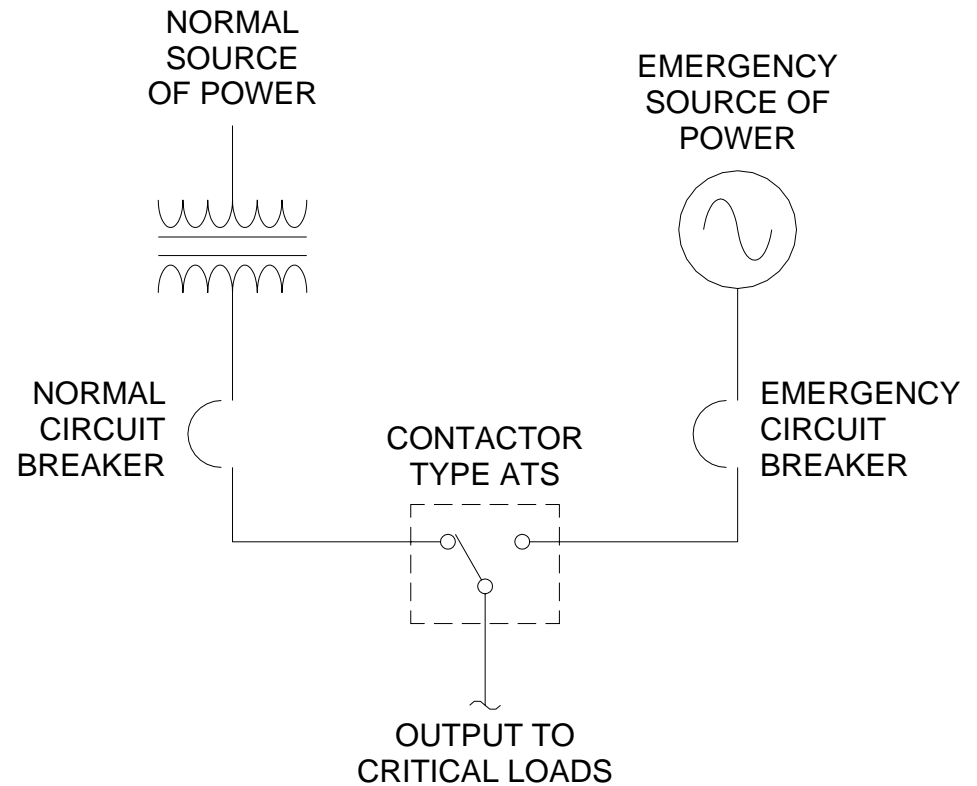

ATS Operation (Loss of Normal Source)

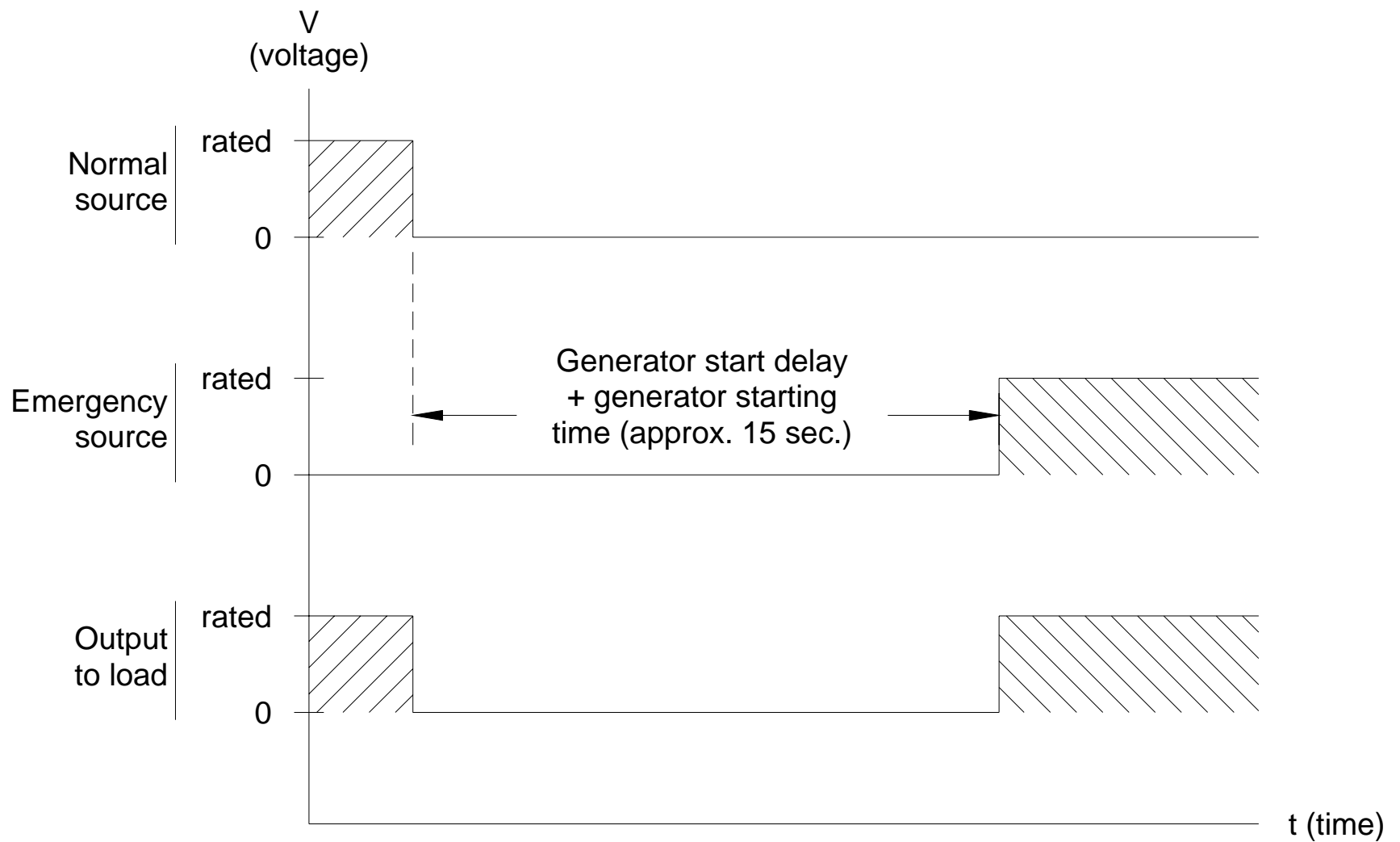

ATS Operation (Open Transition Return)

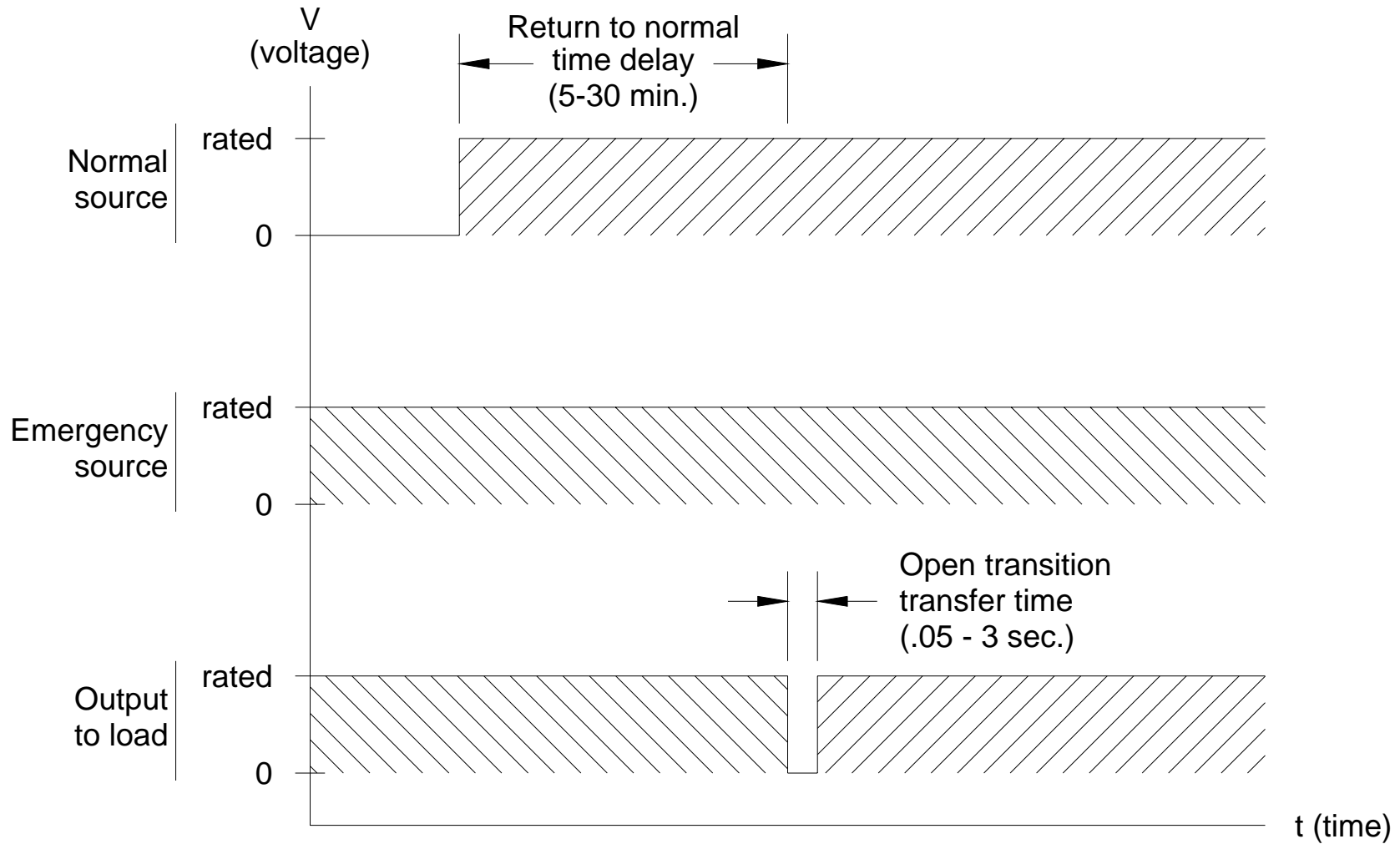

Solid State ATS

- Very Fast transfer
 - (1/4 cycle)
- Very expensive
- Typically used to transfer between 2 constantly available sources

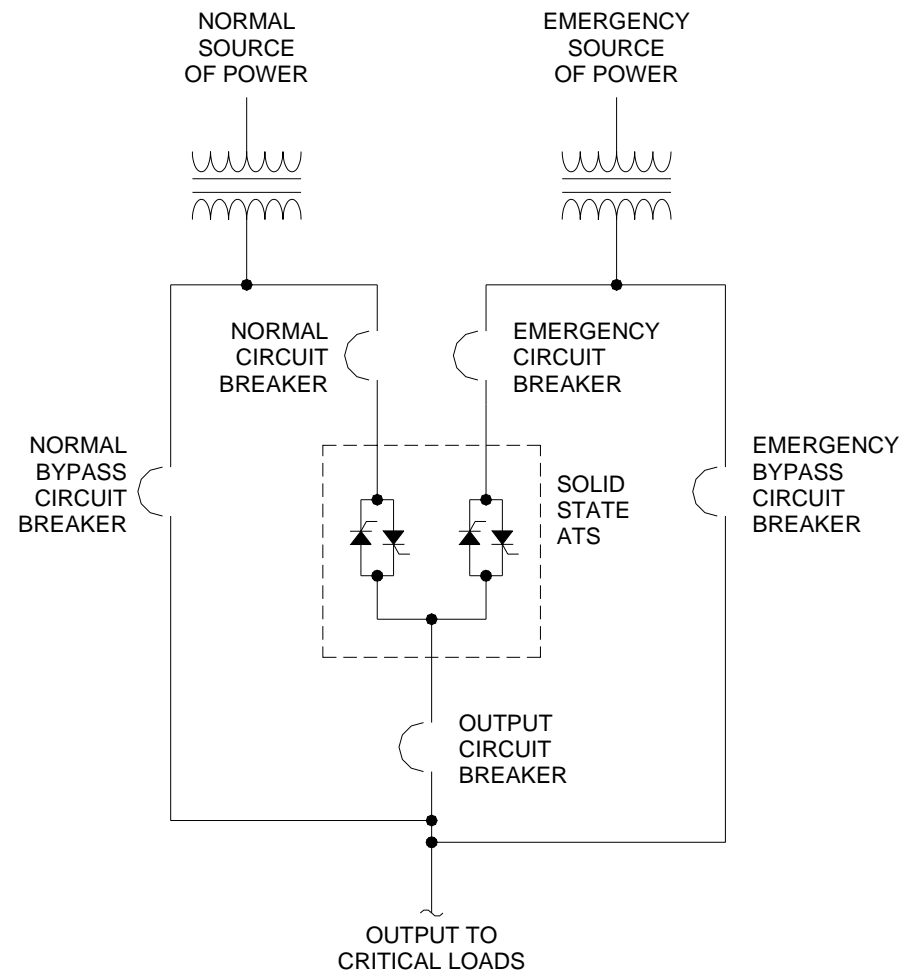

Circuit Breaker Based ATS

- Simple
- Inexpensive
- Power Switching Assy.
 - Molded or Insulated case switch
 - External protection required
 - Molded or Insulated case cb
 - No external protection required
- Open Transition

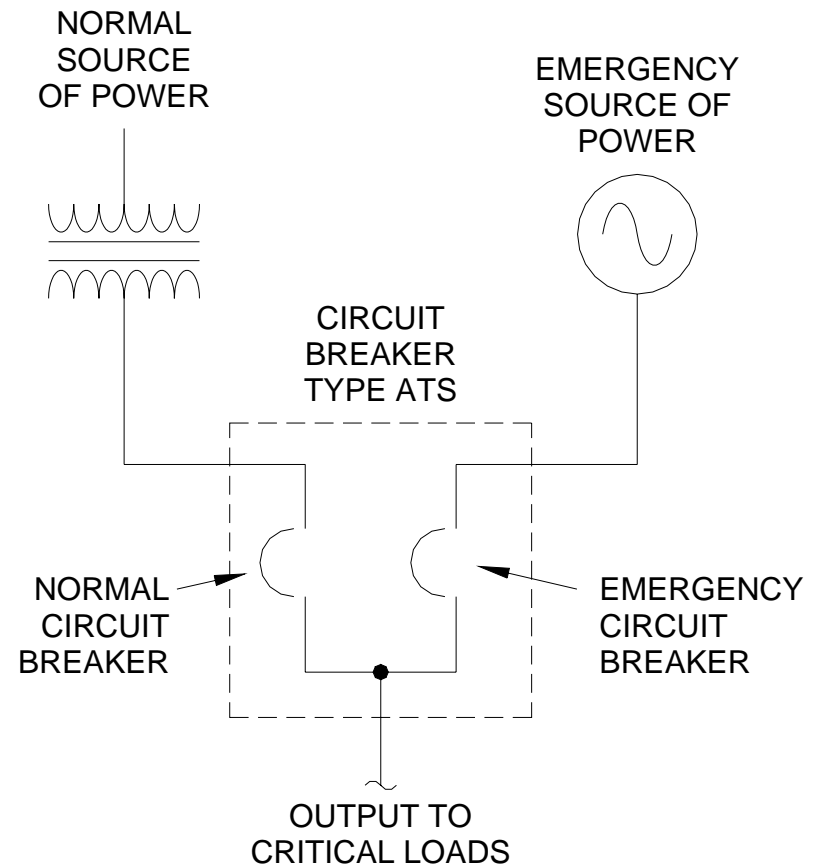

Automatic Transfer Switchboard

- Familiar Circuit Breaker technology
- Open or Closed Transition
 - 100msec or soft transfer
- Active / Passive Synchronization

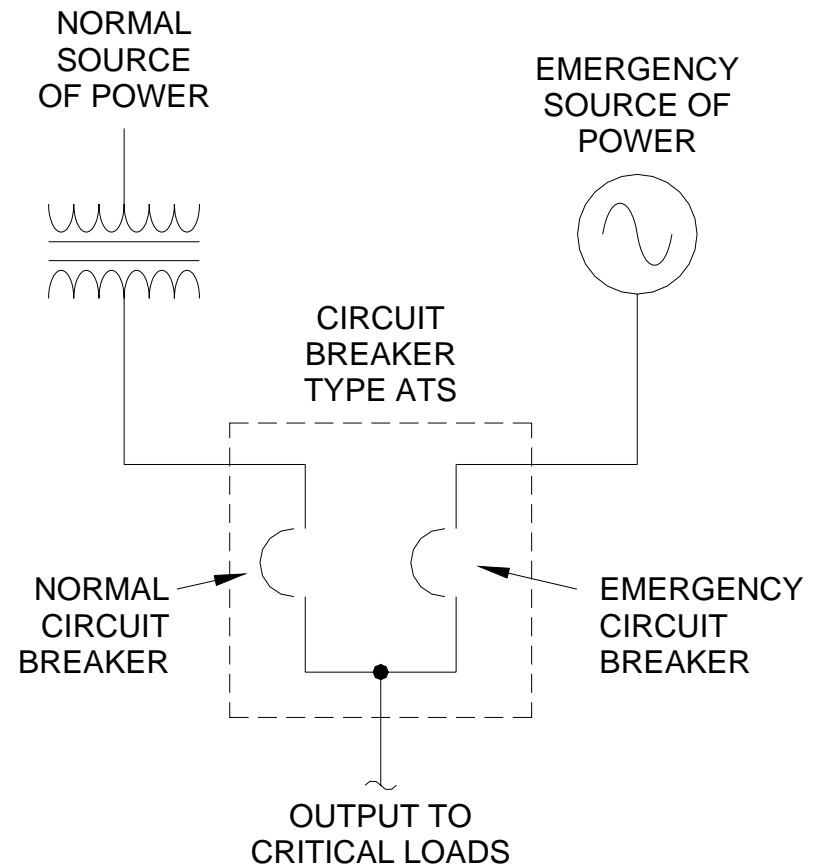

ATSB Operation (Loss of Normal Source)

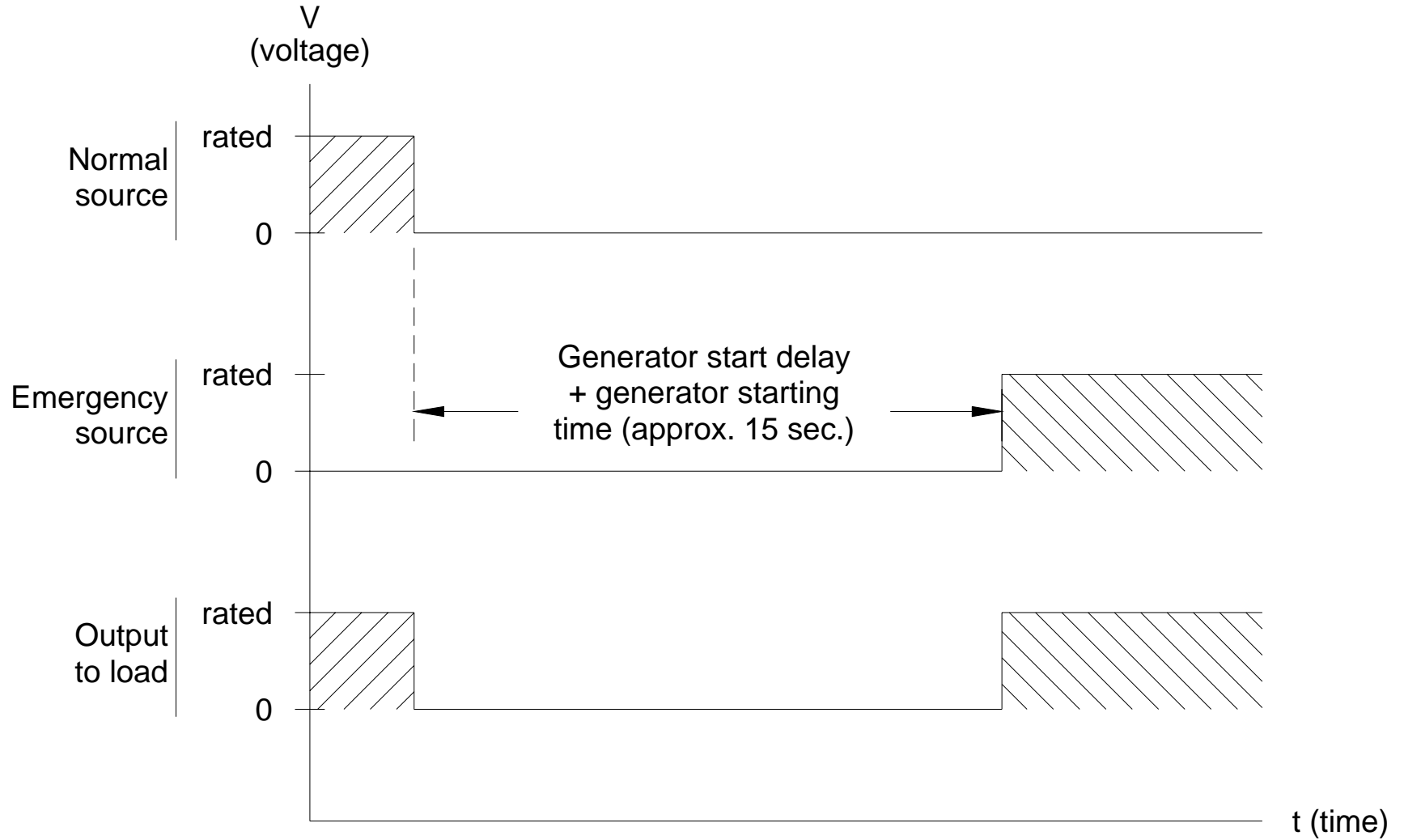

ATSB Operation (Closed Transition Return)

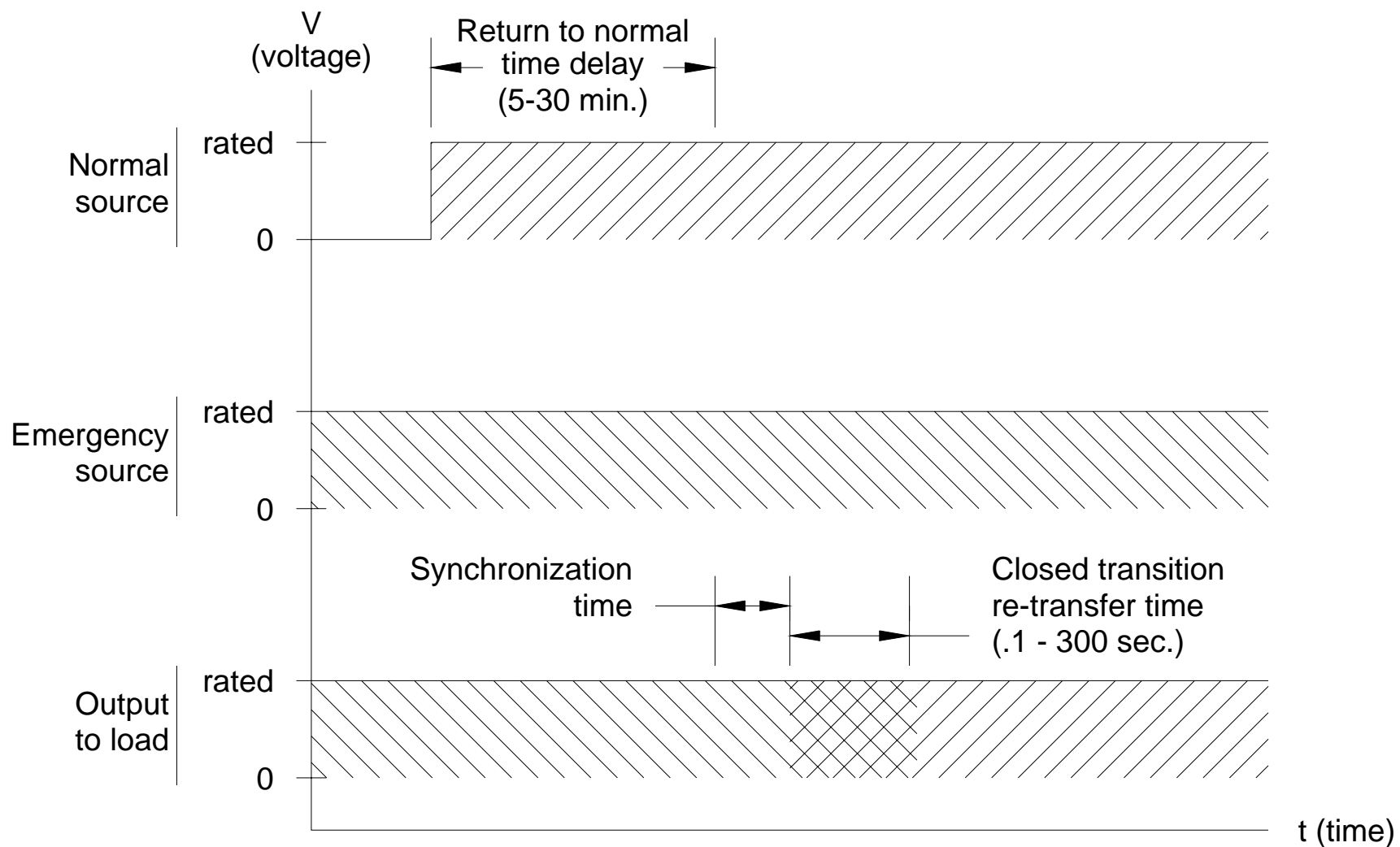

Switchgear

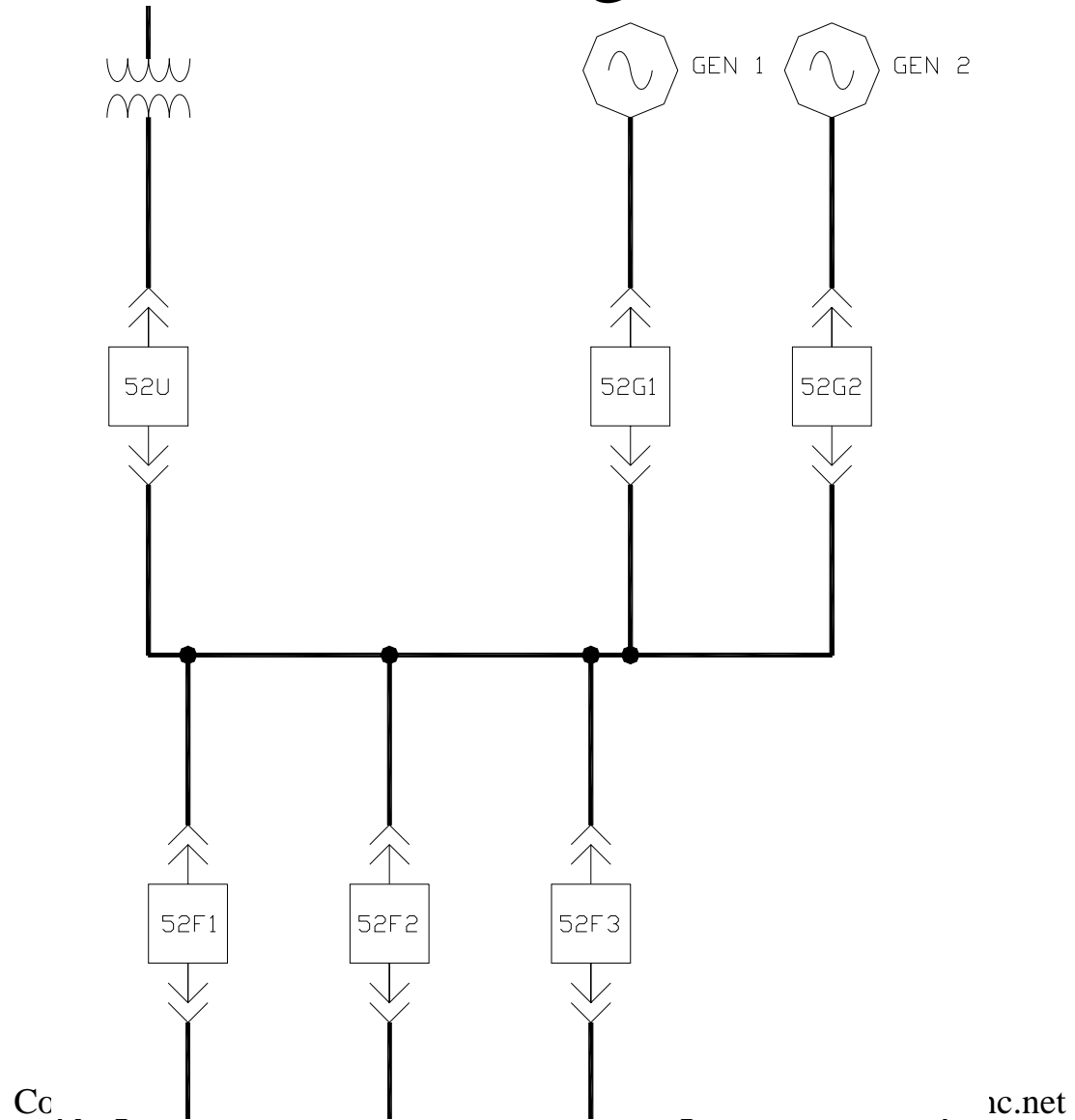

Automatic Transfer Switchgear

- Integration of emergency power source into the plant distribution switchgear

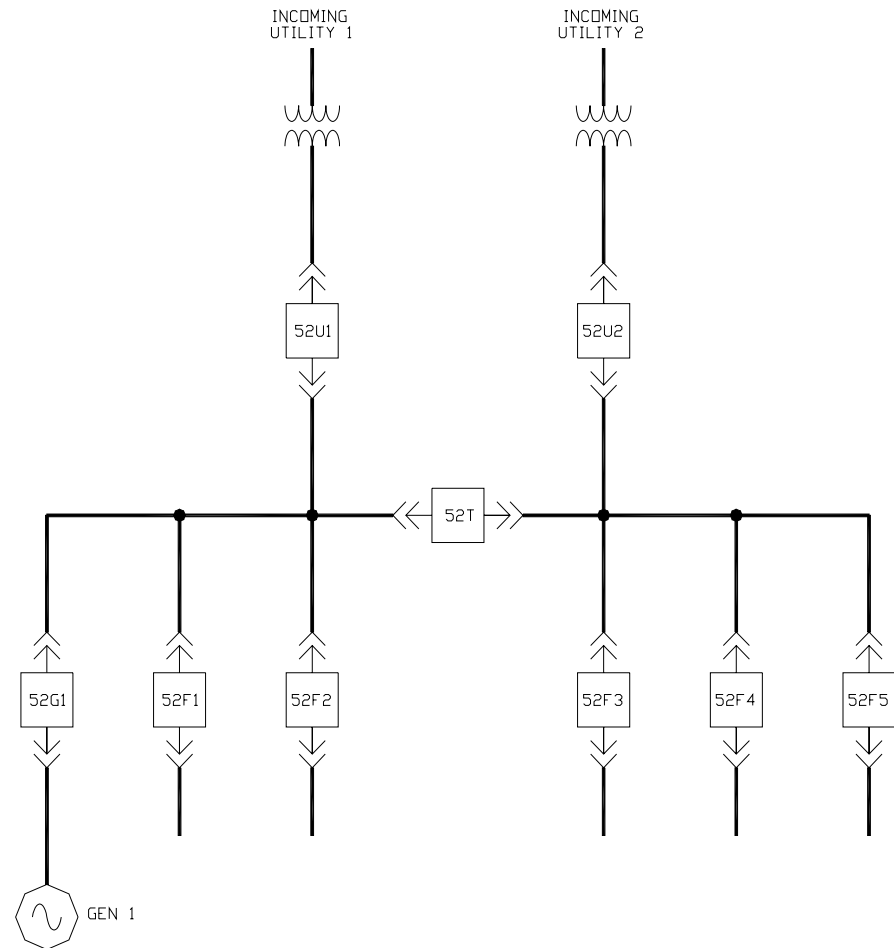

Switchgear

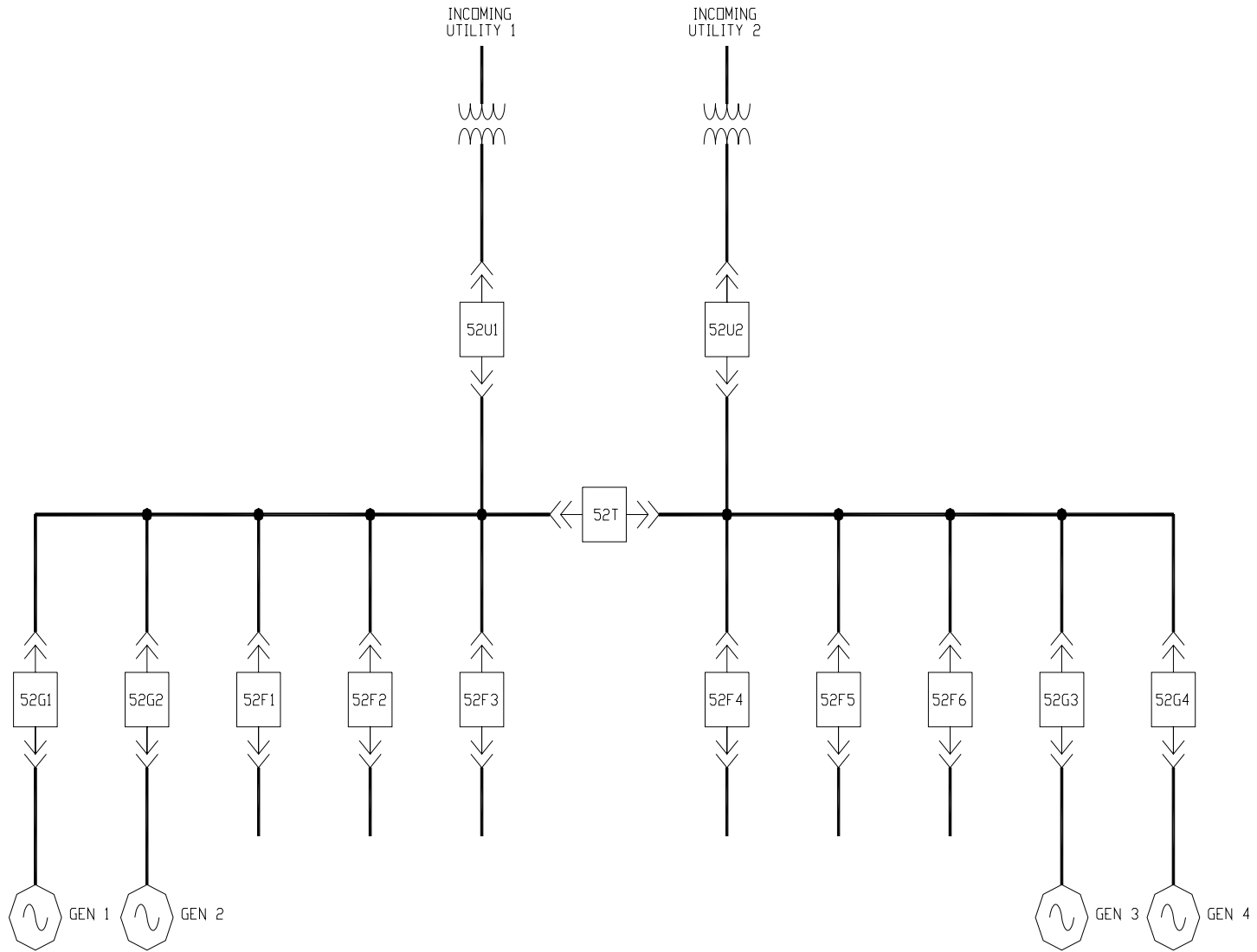

Switchgear

- Back-up generation ready power distribution system design:
 - Provision for connection of generators
 - Equipment configuration
 - Electrically operated circuit breakers, CTs, PTs and other accessories.
 - Segregation of the load to allow cost effective load shedding
 - Site physical layout

Switchgear

- Utility paralleling
 - Load testing of generators
 - Peak shaving
- Single large or Multiple small generators

Peak Shaving

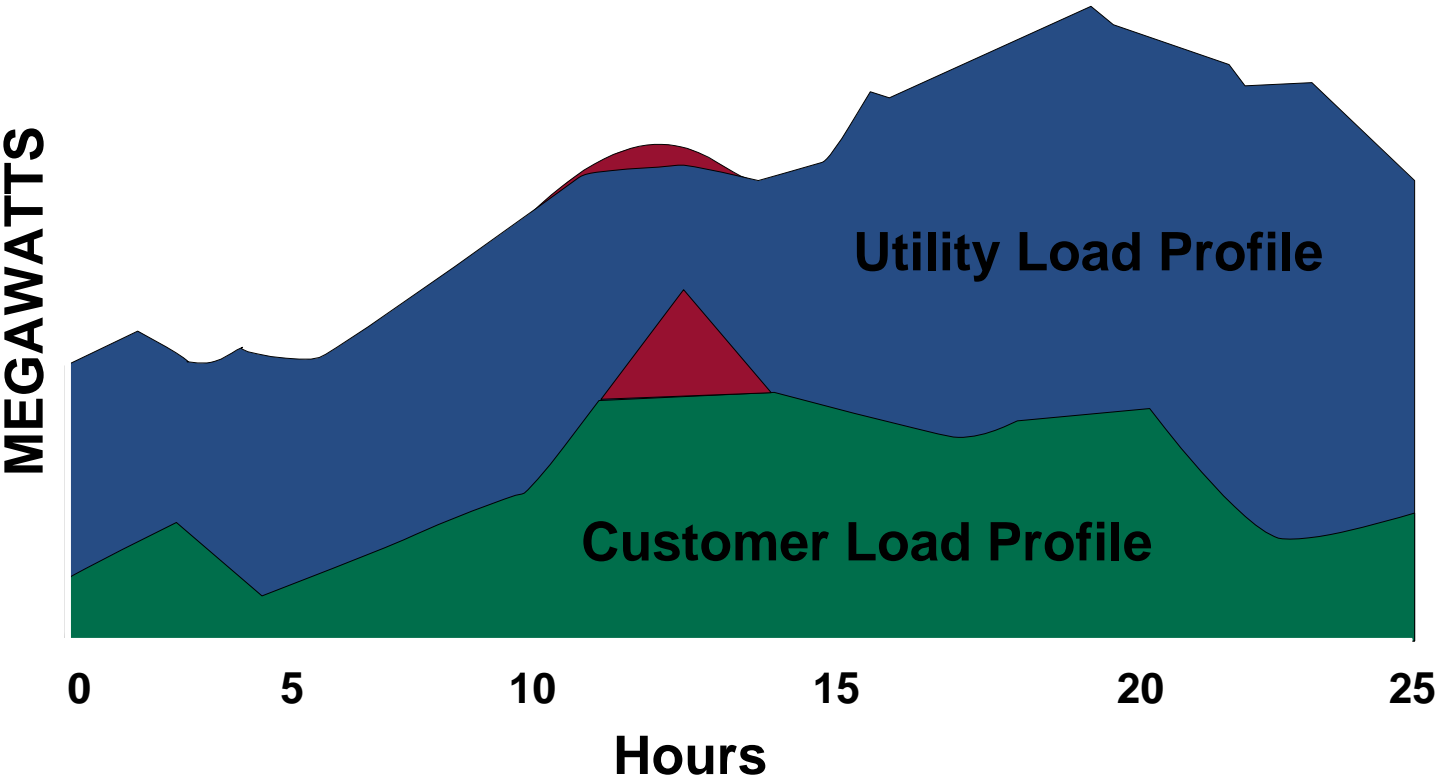

Peak Sharing

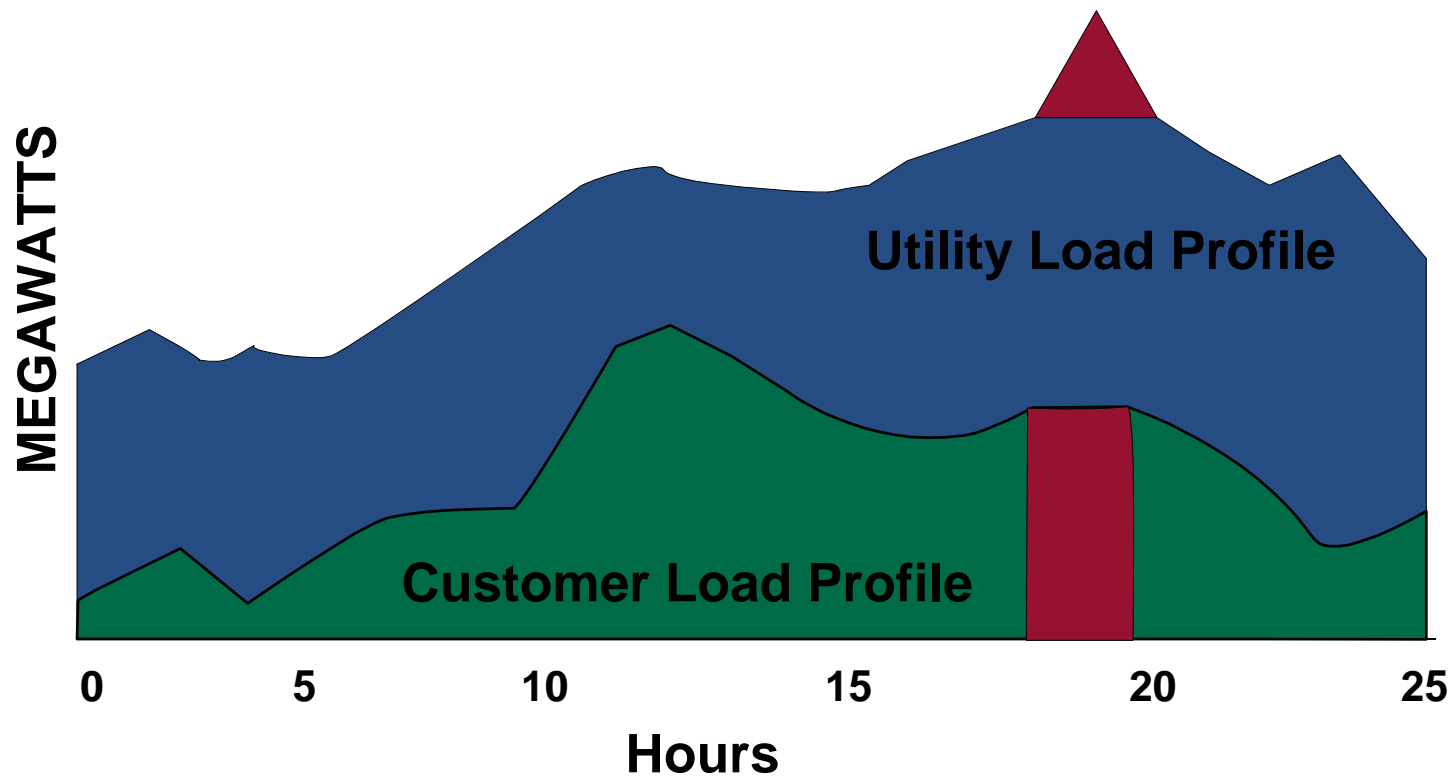

Baseload Control

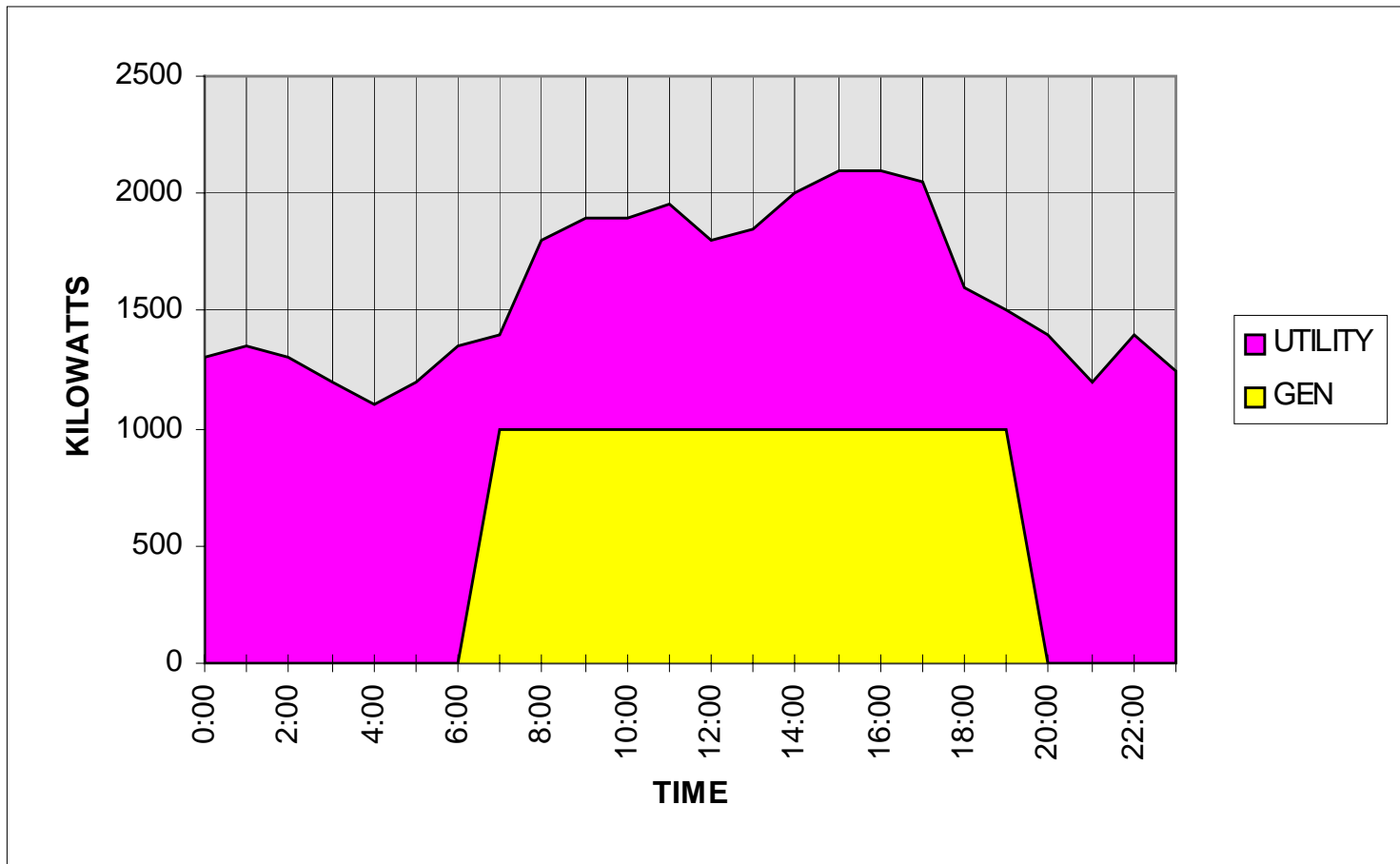

Baseload Control

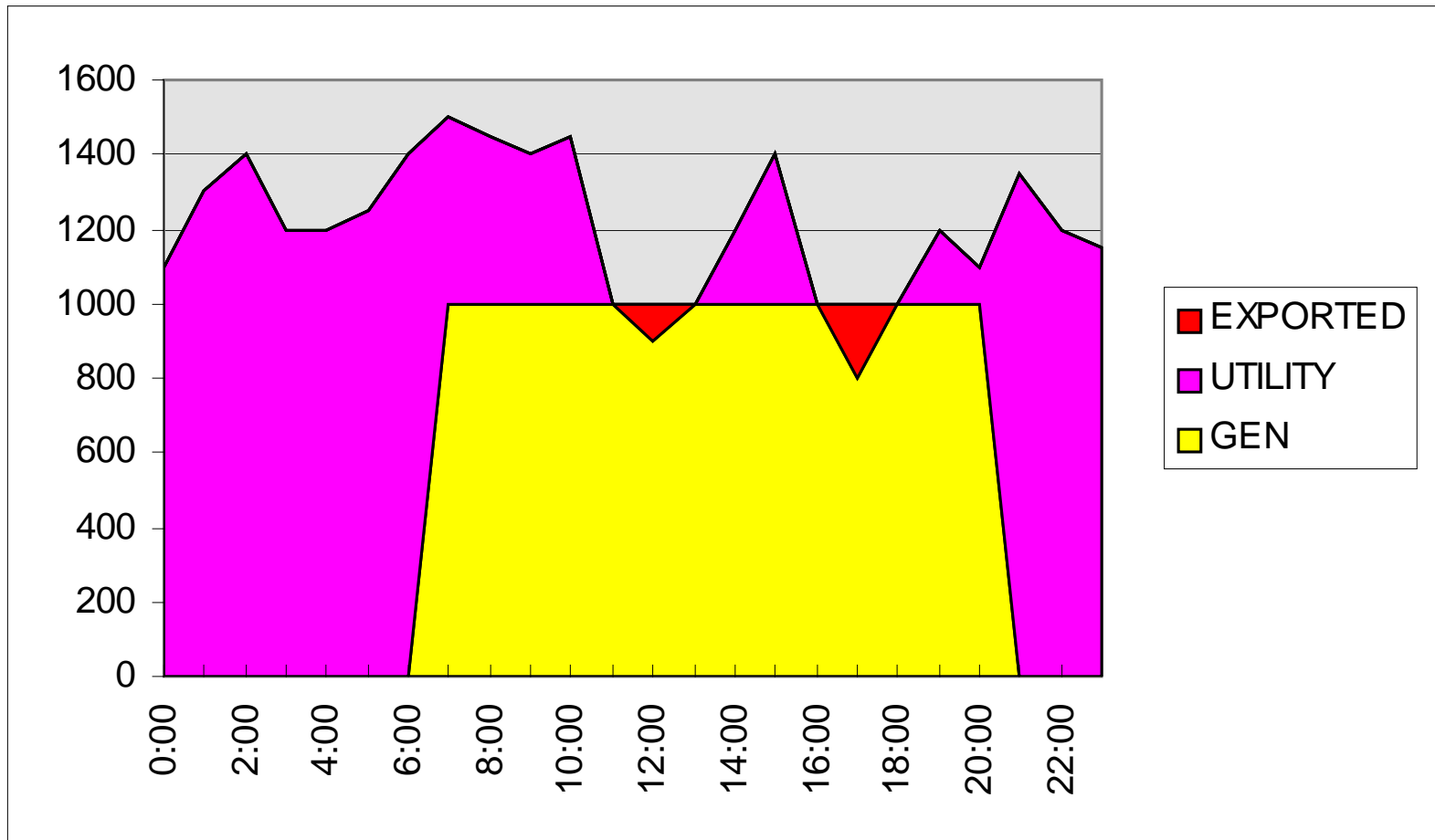

Import Control

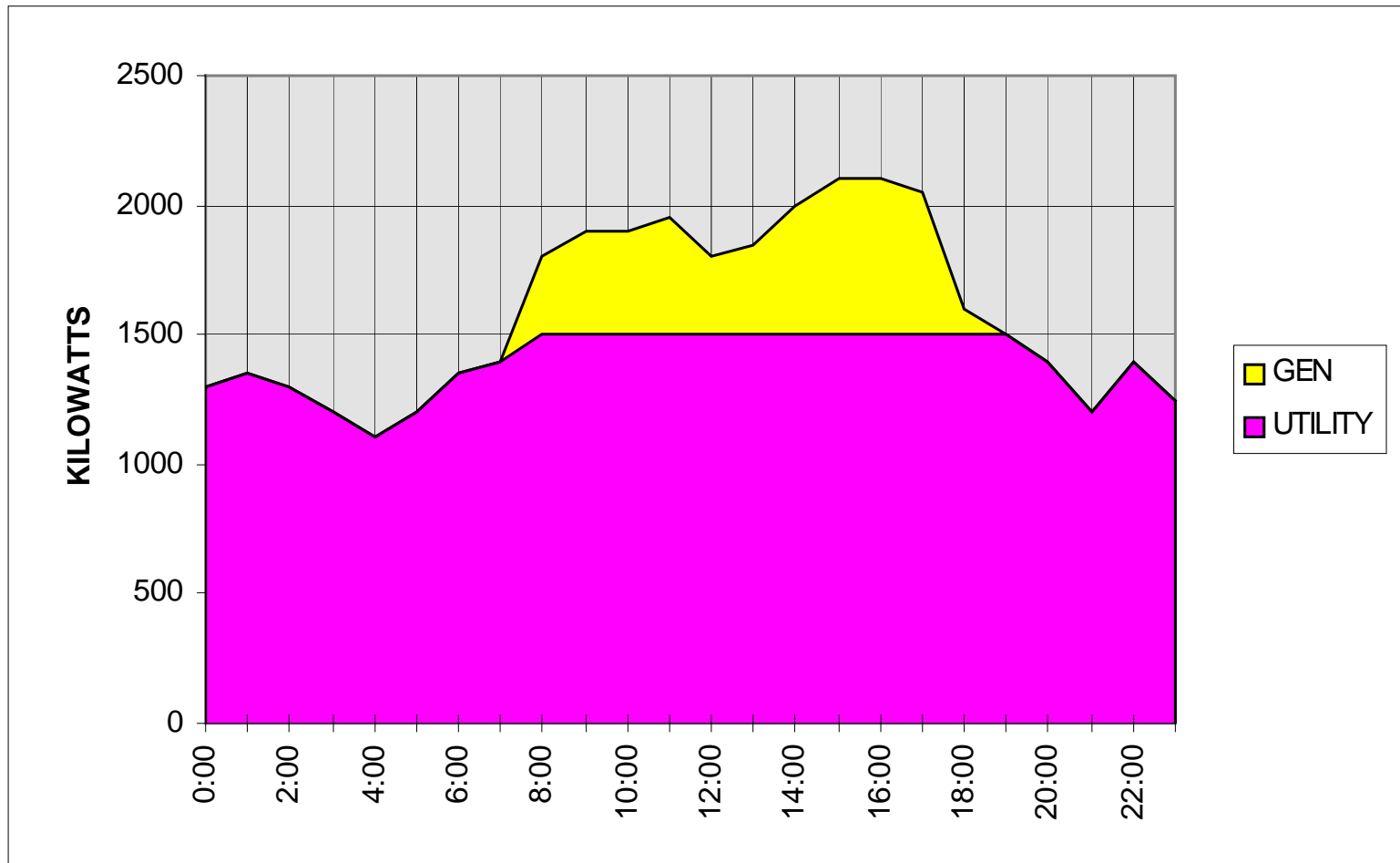

Export Control

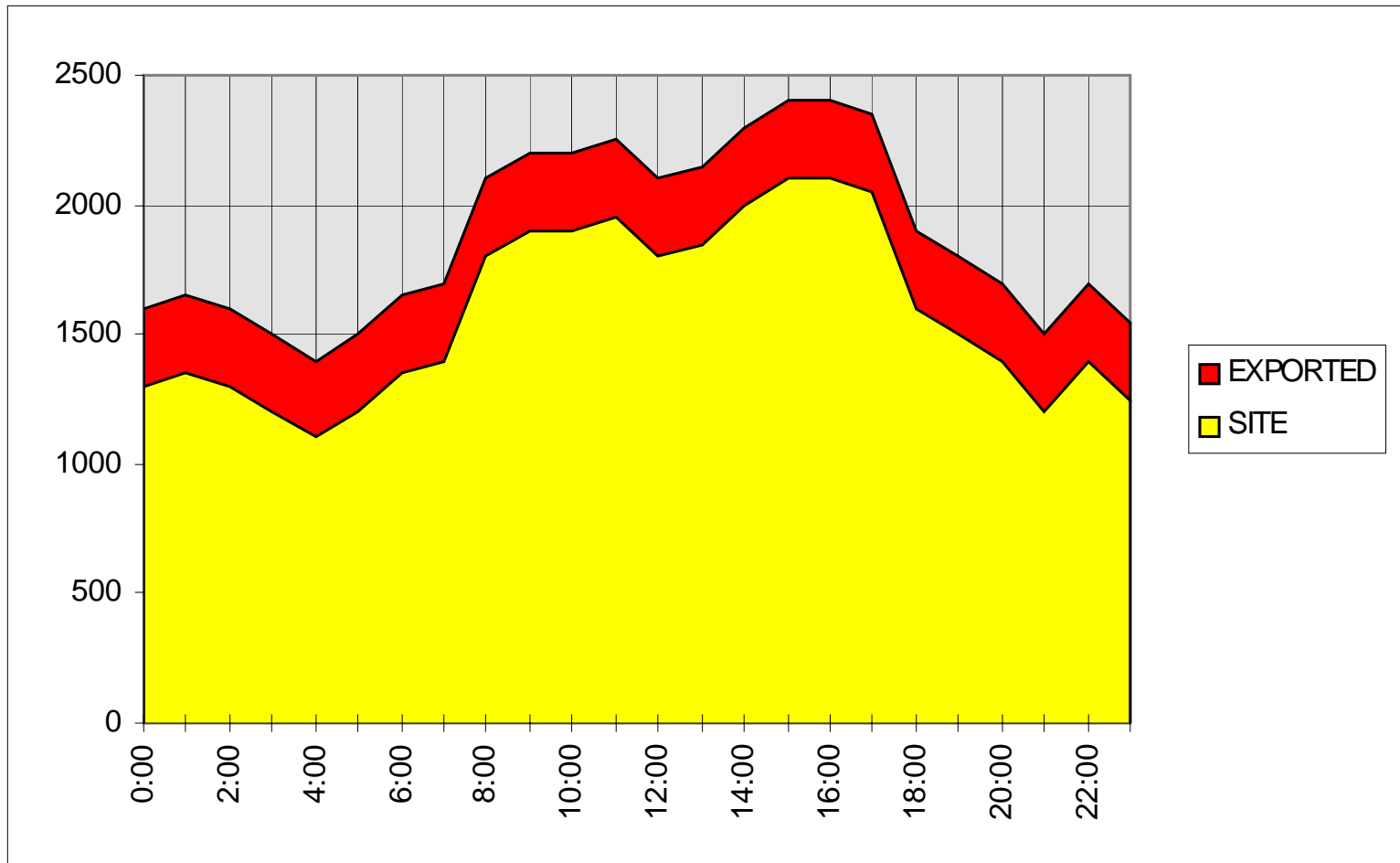

SCADA System

- **Supervisory Control And Data Acquisition**
- System visualization and remote control
- Events and alarm logging
- Email event notification
- Historical data logging
- Full access from remote location
- Ethernet connection
 - Modbus TCP (port 502) interface
 - Http (port 80) web browser interface

SCADA Interface

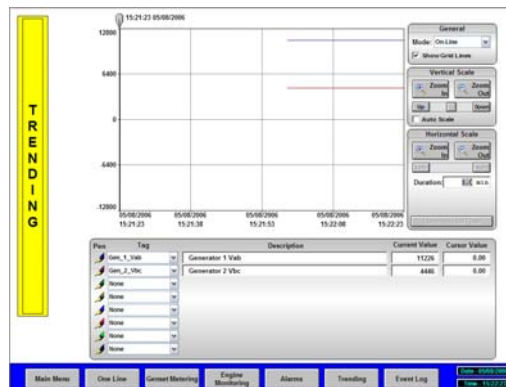
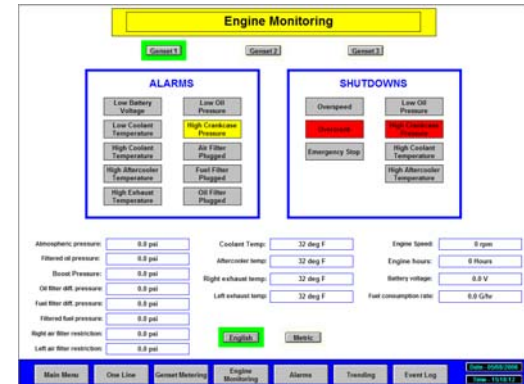
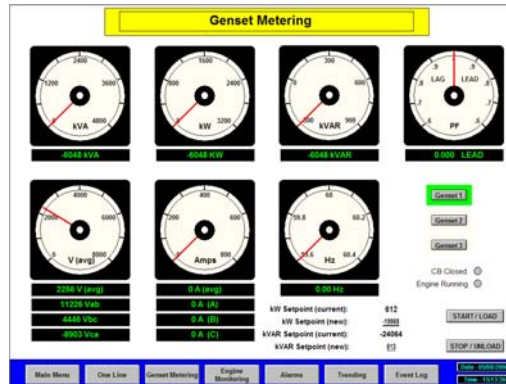
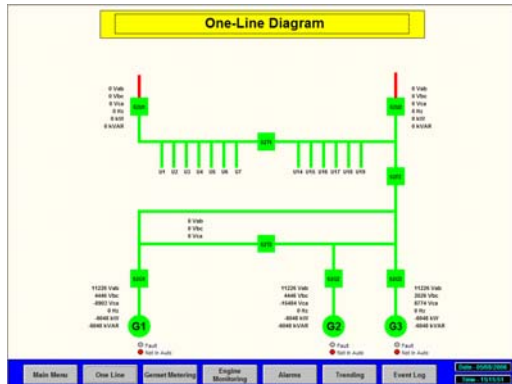

One-Line Diagram

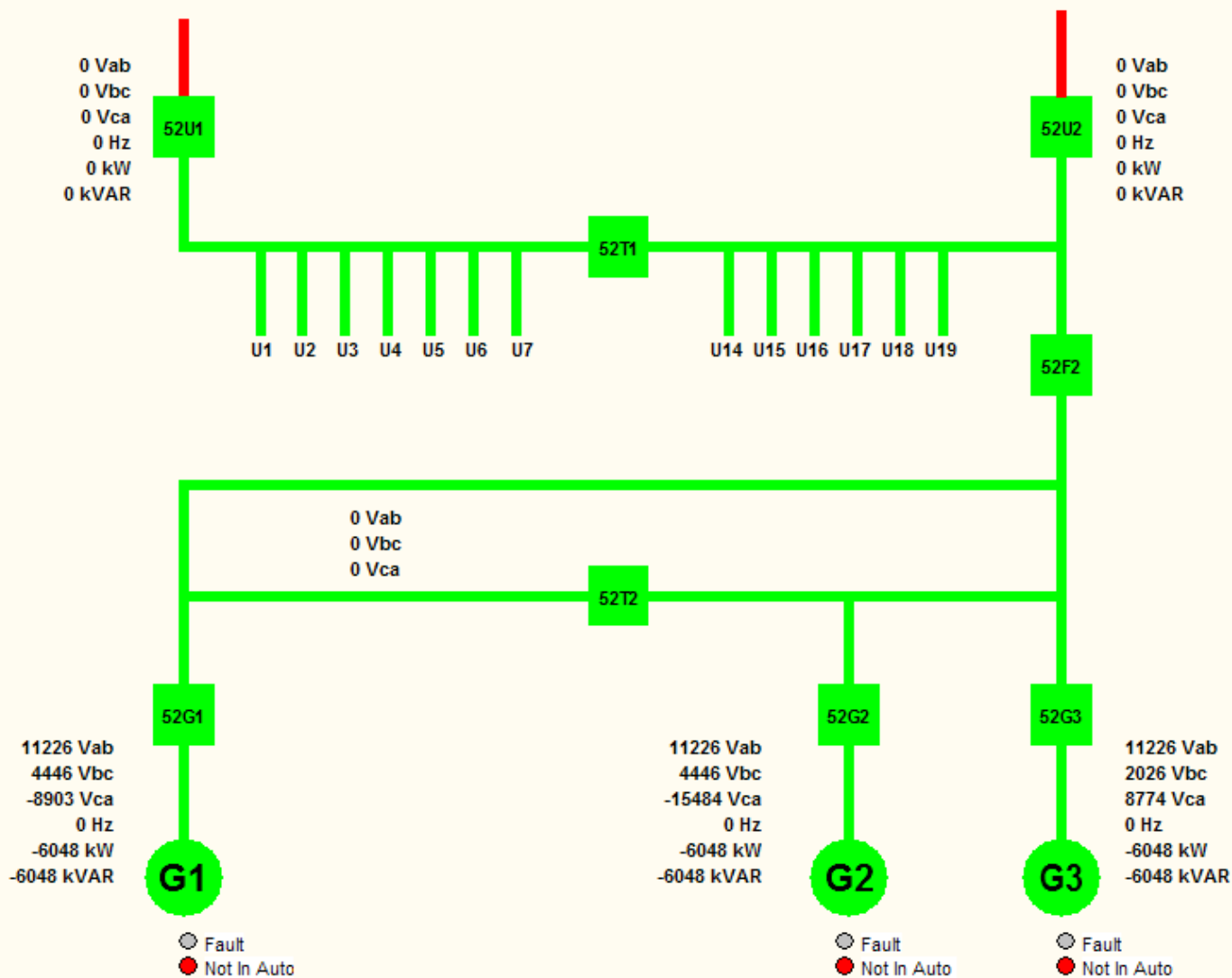

Main Menu

One Line

Genset Metering

Engine Monitoring

Alarms

Trending

Event Log

Date - 05/08/2006

Time - 15:15:51

Genset Metering

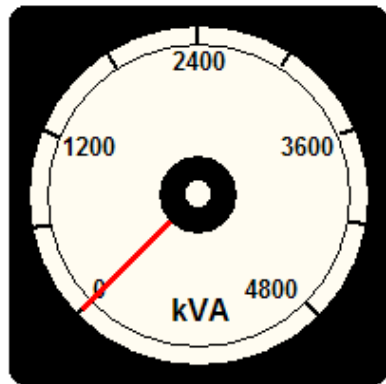

-6048 kVA

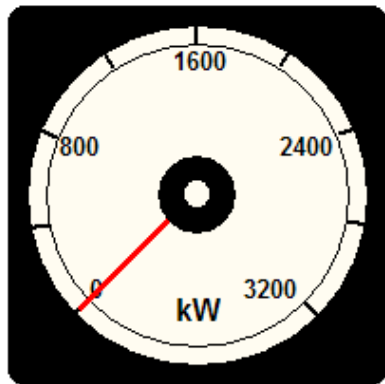

-6048 KW

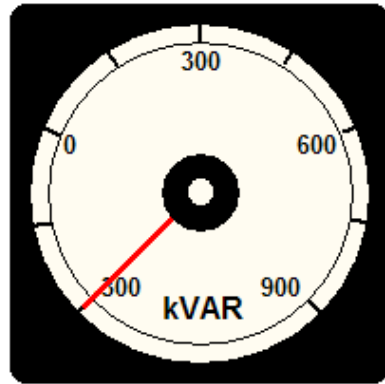

-6048 kVAR

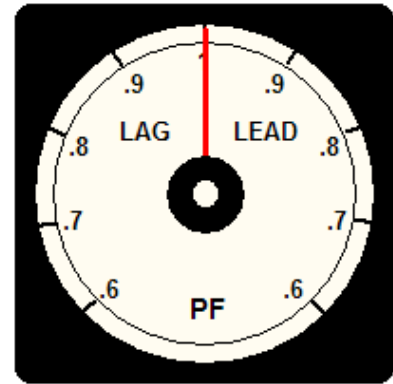

0.000 LEAD

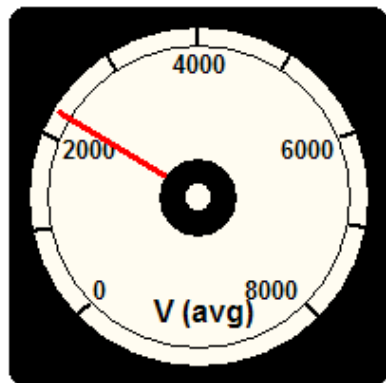

2256 V (avg)

11226 Vab

4446 Vbc

-8903 Vca

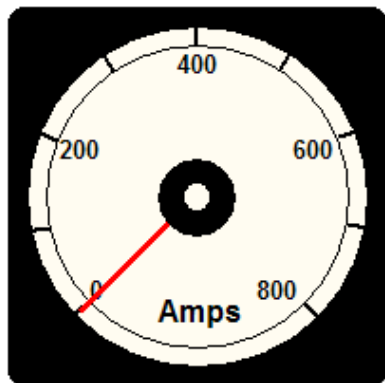

0 A (avg)

0 A (A)

0 A (B)

0 A (C)

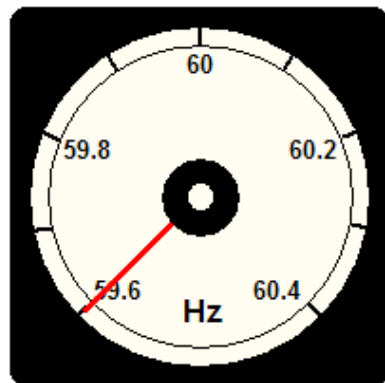

0.00 Hz

kW Setpoint (current):	612
kW Setpoint (new):	<u>-19968</u>
kVAR Setpoint (current):	-24064
kVAR Setpoint (new):	<u>613</u>

Genset 1

Genset 2

Genset 3

CB Closed

Engine Running

START / LOAD

STOP / UNLOAD

Engine Monitoring

Genset 1

Genset 2

Genset 3

ALARMS

Low Battery Voltage	Low Oil Pressure
Low Coolant Temperature	High Crankcase Pressure
High Coolant Temperature	Air Filter Plugged
High Aftercooler Temperature	Fuel Filter Plugged
High Exhaust Temperature	Oil Filter Plugged

SHUTDOWNS

Overspeed	Low Oil Pressure
Overcrank	High Crankcase Pressure
Emergency Stop	High Coolant Temperature
	High Aftercooler Temperature

Atmospheric pressure: 0.0 psi
Filtered oil pressure: 0.0 psi
Boost Pressure: 0.0 psi
Oil filter diff. pressure: 0.0 psi
Fuel filter diff. pressure: 0.0 psi
Filtered fuel pressure: 0.0 psi
Right air filter restriction: 0.0 psi
Left air filter restriction: 0.0 psi











Coolant Temp: 32 deg F
Aftercooler temp: 32 deg F
Right exhaust temp: 32 deg F
Left exhaust temp: 32 deg F

Engine Speed: 0 rpm
Engine hours: 0 Hours
Battery voltage: 0.0 V
Fuel consumption rate: 0.0 G/hr

English

Metric

Alarm Log

	Active Time ▾	Message
	05/08/2006 15:19:33	Genset #1 Overcrank Shutdown
	05/08/2006 15:19:33	Genset #1 High Crankcase Pressure Shutdown
	05/08/2006 15:10:20	Genset #3 Fuel Filter Plugged Alarm
	05/08/2006 15:10:20	Genset #3 High Crankcase Pressure Alarm
	05/08/2006 15:10:20	Genset #3 High Aftercooler Temperature Alarm
	05/08/2006 15:10:20	Genset #3 High Crankcase Pressure Shutdown
	05/08/2006 15:10:20	Genset #2 Overcrank Shutdown
	05/08/2006 15:10:20	Genset #2 High Aftercooler Temperature Alarm
	05/08/2006 15:10:20	Genset #2 High Crankcase Pressure Alarm
	05/08/2006 15:10:20	Genset #2 High Crankcase Pressure Shutdown
	05/08/2006 15:10:19	Genset #1 High Crankcase Pressure Alarm

Main Menu

One Line

Genset Metering

Engine
Monitoring

Alarms

Trending

Event Log

Date - 05/08/2006

Time - 15:20:44

TRENDING

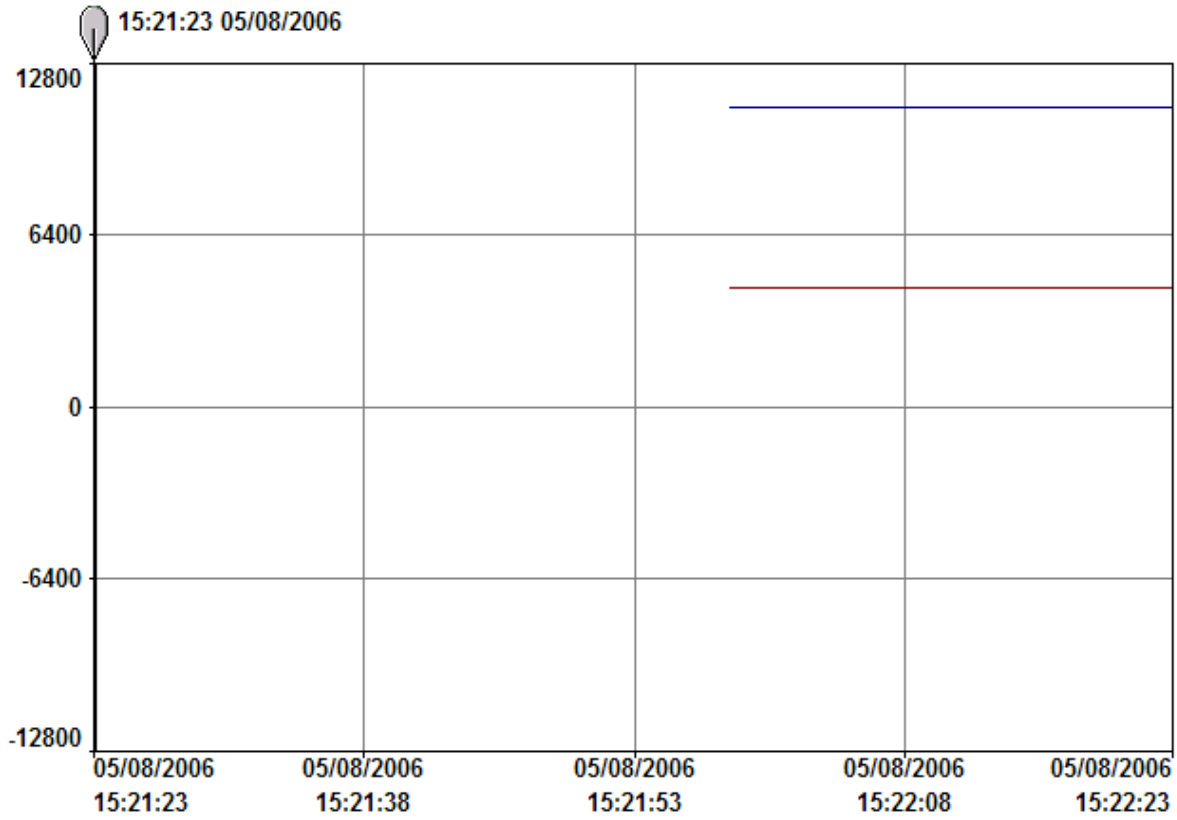

General

Mode: On-Line

Show Grid Lines

Vertical Scale

Auto Scale

Horizontal Scale

Duration: 1.0 min

Pen	Tag	Description	Current Value	Cursor Value
	Gen_1_Vab	Generator 1 Vab	11226	0.00
	Gen_2_Vbc	Generator 2 Vbc	4446	0.00
	None			
	None			
	None			
	None			
	None			
	None			

Event Log

Message	Event Time
Utility #1 Circuit BreakerOpen	05/08/2006 15:45:55
Utility #1 Circuit BreakerClosed	05/08/2006 15:45:37

Main Menu

One Line

Genset Metering

Engine
Monitoring

Alarms

Trending

Event Log

Date - 05/08/2006

Time - 15:46:38

Economics

- Most common source of on-site emergency power is diesel generator set.
 - Typical total cost of installed power system is between \$450 and \$650 per kW
 - Factors affecting installed cost include:
 - Power system voltage
 - Building or outdoor enclosed equipment
 - Fuel storage size and configuration
 - Specified equipment requirements

Economics

- Natural Gas Genset based system.
 - Typical total cost of installed power system is between \$850 and \$1200 per kW
 - Factors affecting installed cost include:
 - Power system voltage
 - Building or outdoor enclosed equipment
 - Specified equipment requirements

Financing

- Alternative financing options through Energy Services Companies
 - Expedite Financing and Construction projects by utilizing Alternative Energy Related financing opportunities
 - Taking advantage of the latest State Legislation
 - Qualifying factors for alternative financing options may include:
 - Savings in water consumption costs, wastewater usage costs and other operating costs, and increase of billable revenues
 - Guaranteed savings, Energy, Operations and Capital avoidance.











Copyright © 2006 Advanced Power Technologies, Inc. www.apvinc.net