

Listing of most common types of currently available automatic transfer switching devices, description of their operation and overview of their suitability for various applications.

A commonly available transfer switching device on the market is called Automatic Transfer Switch (ATS). An ATS is a device, which automatically transfers one or more load conductors from the “Normal” power source to an “Emergency” power source and back.

All ATS consist of a Power Switching Assembly (PSA), Control Unit Assembly (CUA) and the enclosure.

Three most common types of ATS by the type of the Power Switching Assembly used are: contactor based, circuit breaker based and solid state.

Contactor based ATS.

Contactor based ATS is the most common type by the number of units installed. Some of the advantages of the contactor based ATS are low cost and availability. The contactors are known as the devices designed for frequent switching of the load current and commonly used as a part of the motor starters. However many contactor based ATS manufacturers do not use traditional contactors in their PSA. Therefore most contactor based ATS are not rated for the number of switching operations (with or without load) as traditional contactors. Majority of the contactor based ATS manufacturers design their PSA to meet the requirements of the UL 1008 standard as indicated below:

**UL 1008 Table 30.2
Endurance test cycles**

Switch rating	Rate of operation	Number of cycles of operations		
		With current	Without current	Total
0 – 300	1 per minute	6000	–	6000
301 – 400	1 per minute	4000	–	4000
401 – 800	1 per minute	2000	1000	3000
801 – 1600	1 per 2 minutes	1500	1500	3000
1601 and above	1 per 4 minutes	1000	2000	3000

Traditional contactor base ATS is neither capable nor intended to interrupt a fault current. Therefore UL 1008 standard specifies the minimum fault currents the switch should be able to withstand without damage for a time period of at least 3 cycles. (50 mS):

UL 1008 Table 34.1
Available short-circuit current

Switch Rating	Current in Amps
100 A or less	5,000
101-400 A	10,000
401 A or greater	20 times rating but not less than 10,000 A

Power systems with the contactor based ATS must have a circuit breaker or a fuse upstream from the ATS (for each power source: normal and emergency) for the purpose of short circuit protection. See figure 1 below:

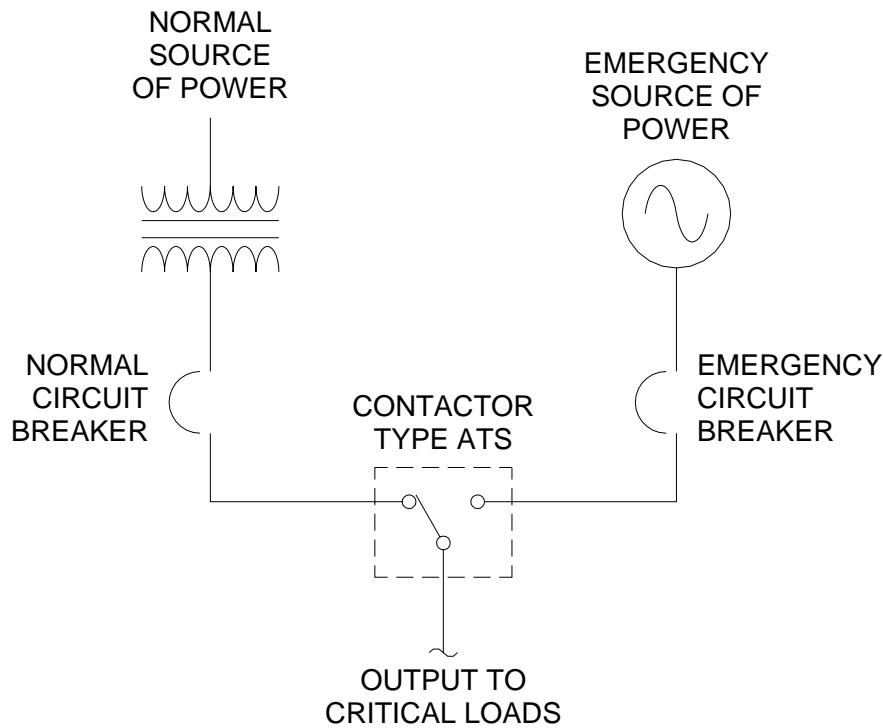

Figure 1. Contactor Based ATS Diagram

If the ATS is rated to be able to withstand the available fault current for only 3 cycles, the upstream protective device shall interrupt the fault in less than 3 cycles. This means that there is no practical way of coordinating the upstream short circuit protective device with any of the short circuit protective devices downstream from the ATS. As a result, a short circuit anywhere in the critical circuit fed by the ATS will cause operation of the upstream short circuit protective device with the consequent loss of power all the critical circuits fed by the ATS.

At the same time, if the fault is in one of the critical circuits protected by a feeder circuit breaker with the instantaneous protection, the feeder circuit breaker may clear the fault.

Operation of the short circuit protective device upstream from the ATS will look to the ATS as a loss of the present source and will cause the ATS to transfer the critical load to the alternative power source. If the fault in the critical load circuit was cleared by the down stream feeder circuit breaker, than the remaining critical load circuits will be energized by the alternate power source. . If the fault in the critical load circuit was not cleared by the downstream feeder circuit breaker due to the fault location, tripping time, uncoordinated tripping setpoints or feeder circuit breaker malfunction, transferring of the faulted critical load circuit to the alternate power source will cause further damage to the faulted circuit as well as tripping of the alternate power source upstream from the ATS

Circuit breaker based ATS.

Circuit breaker based ATS typically uses two interlocked, electrically operated circuit breakers as the heart of its PSA. The circuit breaker types, typically used in the ATS PSA are designed to comply with the UL 489. There are two major types of the circuit breakers, which fall in this category. The industry calls them molded case circuit breakers and insulated case circuit breakers. Molded case circuit breakers are the most basic type of circuit breakers, commonly found in low voltage power systems. The trip units typically include overload protection and short circuit protection (instantaneous setting of approximately 5 to 10 times frame rating). Insulated case circuit breakers are designed with stored energy mechanism and spring charging motor for remote closing, and are commonly available in draw-out construction.

The circuit breakers used in the PSA assembly may be with or without the trip unit. Even when used without the trip unit, most circuit breakers will trip and interrupt the fault, when the level of fault current exceeds the withstand rating of the circuit breaker. This self-protecting feature is one of the advantages of a circuit breaker based PSA over a contactor based PSA.

Generally, a circuit breaker based ATS acts the same as a contactor based ATS. Circuit breaker based ATS can integrate the functions of an ATS and normal and alternate sources short circuit protective devices when supplied with the trip units.

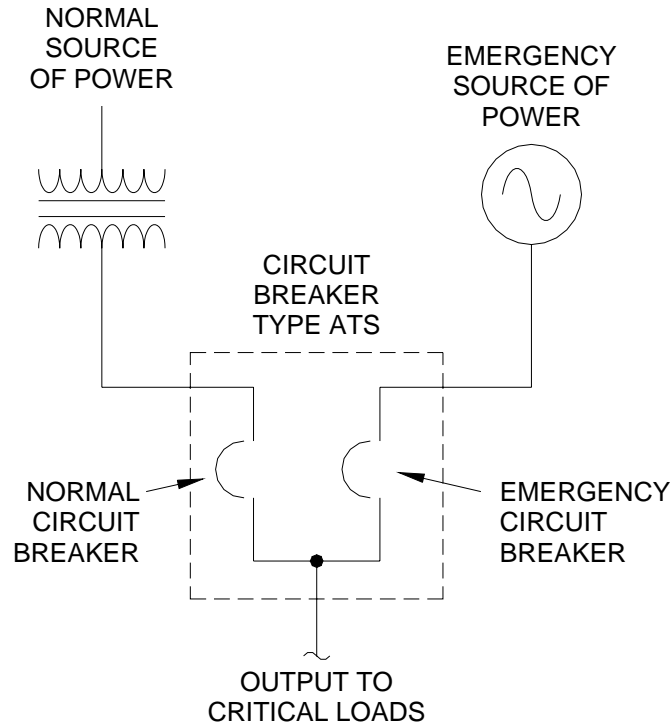

Figure 2. Circuit Breaker Based ATS Diagram

If the time delays to transfer setpoints are short, and under certain power system conditions it is possible that the ATS will try to transfer during a fault. In that case a circuit breaker type ATS will be able to successfully disconnect the faulted load and complete the transfer, since the circuit breakers are rated to interrupt fault current. A contactor based ATS is likely to fail under the same scenario, since the PSA contactors are not rated to interrupt fault.

Solid state ATS.

Solid state ATS PSA is based on the use of the heavy duty Silicon-Controlled Rectifiers (SCR). Use of SCRs in conjunction with the microprocessor based control unit allows the solid state ATS manufacturers to sense the failure of the normal source and transfer to the alternate source in less than $\frac{1}{4}$ of a cycle. This transfer time is fast enough to not affect the operation of the common computer equipment.

Due to the solid state nature of the SCR based PSA it is common to see an isolation and bypass circuit breakers on each source side and load side of the ATS. The isolation circuit breakers allow for visible disconnection of the SCR units from each source and load in case of the SCR units failure or need for

maintenance. After the SCR unit has been fully disconnected by the isolation circuit breakers, one of the bypass circuit breakers can be closed to directly energize the load by the selected power source.

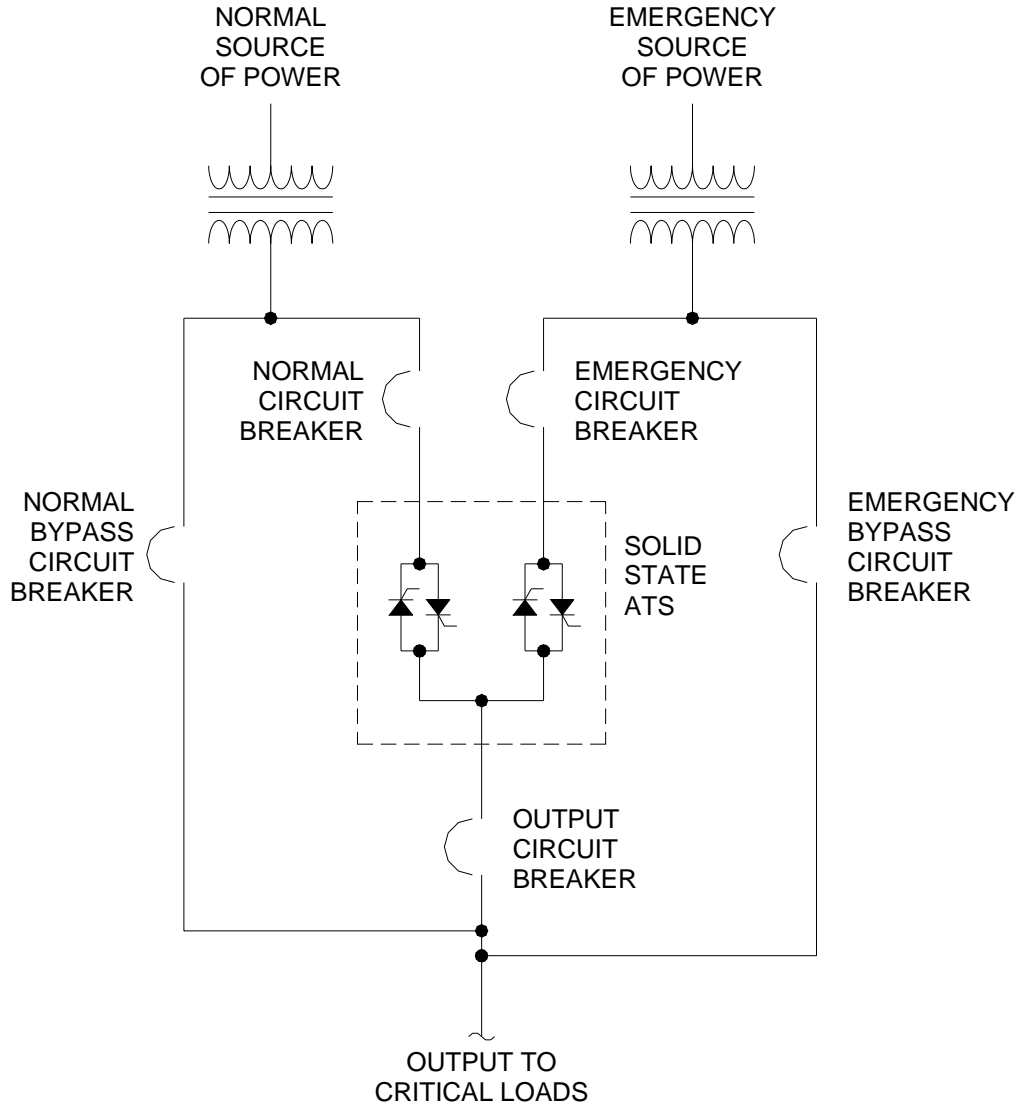

Figure 3. Solid State ATS Diagram (shown with bypass isolation circuit breakers)

Application and operation.

Contactor and circuit breaker based transfer switches:

The most common application of the contactor and circuit breaker based transfer switches is when they are used in conjunction with the emergency generator. In this case the utility is connected to the normal side of the ATS, the generator is connected to the alternate (emergency) side of the ATS.

Upon utility failure, the ATS will issue a start signal to the emergency generator set after a typical time delay of 1 to 5 seconds. This time delay is intended to avoid starting of the generator set during very short interruptions of the normal power supply. These short interruptions are typically corrected by the upstream utility source reclosing, within 2 seconds.

Once the generator set receives a start signal from the ATS, it takes approximately 10 seconds for the generator to build up voltage and frequency to become available to energize the load. At this time the transfer from the normal to the emergency source will occur. The load is now energized by the emergency source.

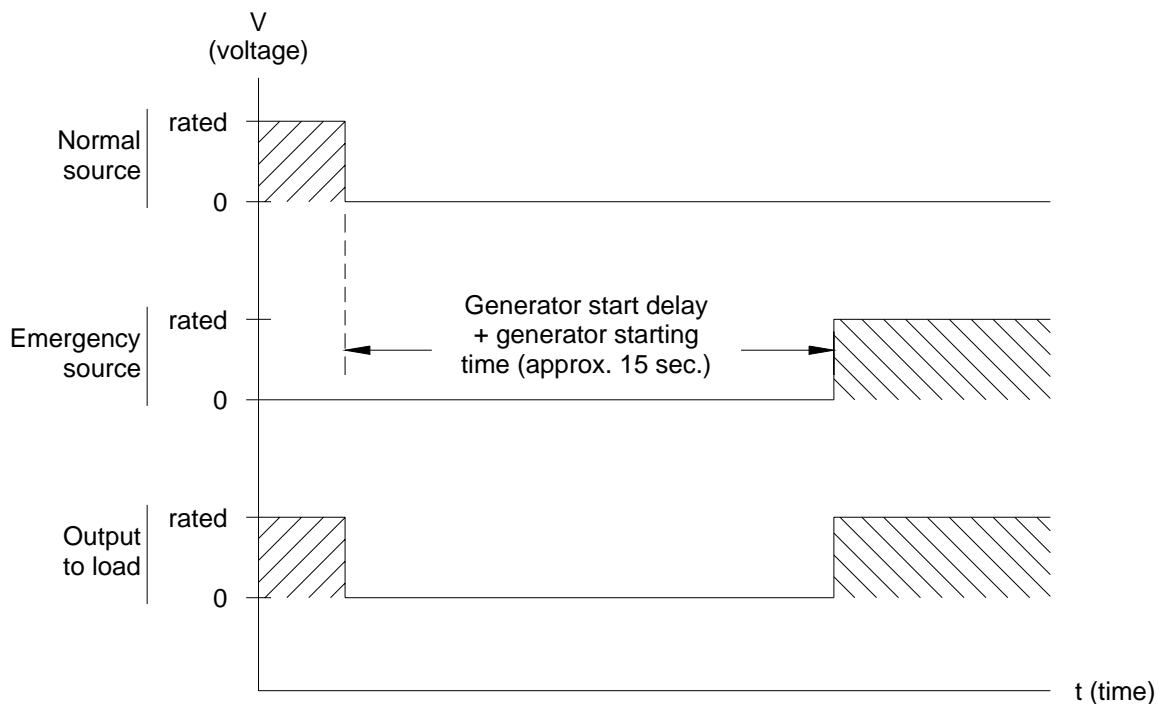

Figure 4. Contactor / Circuit Breaker ATS
Transfer to Emergency Source

Upon utility return, the ATS will activate the time delay return to normal source. This time delay is typically set anywhere between 5 minutes and 30 minutes. This allows to ensure that the utility source has returned to stay as well as gives the generator set some minimum time to run under load as well as allows some minimum time to recharge the generator set engine cranking batteries in case the utility was to fail again, shortly after the transfer to the normal source. Upon expiration of this time delay the transfer from the emergency source to the normal source will occur.

Transfer between the two live sources:

There are two ways to transfer load between the two live sources: **open transition** and **closed transition**. Most of the time the transfer between the two live sources will occur when transferring from the emergency source back to the returned normal source, therefore all our discussion bellow will be based on this transition. However the phenomenas described below apply to any load transfer between the two live sources.

During the **open transition transfer** from the emergency source back to the returned normal source, the emergency source will be disconnected before the normal source will be connected. This will cause a brief outage to the load.

Before we discuss pros and cons of the different ways to accomplish the open transition load transfer, let's examine the phenomena of the open transition transfer of the **motor and transformer loads**.

Every power systems engineer knows that when the voltage to the running electric motor suddenly decays, the electric motor begins to act as the generator for a short period of time. The duration of the generator action depends on the type of the motor, inertia of the driven equipment as well as the amount of the passive load on the same circuit. This phenomena causes the power systems engineers to consider motor contribution when they calculate the available fault current. During the open transition load transfer, the independent sources are likely not to be synchronized. Fast open transition motor load transfer, can cause connection of the generating motor to the power source out of synchronism. The consequences of this connection are similar to the closing the generator out of synchronism: high line currents (with possible operation of the overcurrent devices) and mechanical stress to the equipment shafts and gears (with possible mechanical damage). Transformers are also known to cause high line currents during fast open transition load transfers, due to the stored magnetic field.

There are three most common ways to accomplish this transfer: **non-delayed transition**, **in-phase transition**, and **time delayed transition**.

In case of **non-delayed transition**, the normal source will be connected to the load as soon as the emergency source is disconnected from the load, without any intentional time delay. Advantages: the duration of the outage is minimized;

lowest cost. Disadvantages: not suitable for transferring large inductive loads (motors, transformers, etc.).

In case of **in-phase transition**, the normal source will be connected to the load as soon as the emergency source is disconnected from the load, but the transfer will only take place when the two sources are in synchronism. Advantages: the duration of the outage is minimized. Disadvantages: relies on the generator to passively fall into synch with the utility, which is not always possible. In this case the transfer may not occur until the generator runs out of fuel. If the substantial passive load is connected to the motor during the transfer, the motor may fall out of synch faster than the transfer time of the ATS. The time of transfer is not predictable. Does not eliminate inrush during transfer of the heavy transformer loads.

In case of **time delayed transition**, the normal source will be connected to the load after the emergency source is disconnected from the load, and after an adjustable time delay. Advantages: the most reliable and flexible operation suitable for reliable transfer of any loads. Disadvantages: the duration of the outage during transfer is increased.

System operation of a typical open transition ATS is described below:

Upon sensing of the utility failure (utility voltage is not within undervoltage setpoint) the Time Delay Engine Start timer shall start timing. If utility failure condition remains upon expiration of the Time Delay Engine Start timer the generator set shall be automatically started and brought up to speed and voltage. At that time utility circuit breaker shall open and generator circuit breaker shall close (after adjustable time delay neutral). At this time the generator is supplying power to the site load. Upon sensing of utility return (utility voltage is within set undervoltage tolerance) the Time Delay Emergency to Normal timer shall start timing. If utility power remains healthy (utility voltage is within set undervoltage tolerance) upon expiration of the Time Delay Emergency to Normal timer the generator circuit breaker shall open and the utility circuit breaker shall close (after adjustable time delay neutral). At this time the generator set shall be put in the cooldown mode of operation.

Time Delay Neutral shall determine the minimum time period the load will be deenergized before the load is energized from the alternative source (normal or emergency).

If the generator set should fail (generator voltage is not within undervoltage setpoint) while Time Delay Emergency to Normal timer is timing, the Time Delay Emergency to Normal timer shall be bypassed, generator circuit breaker shall open and the utility circuit breaker shall close (after adjustable time delay neutral).

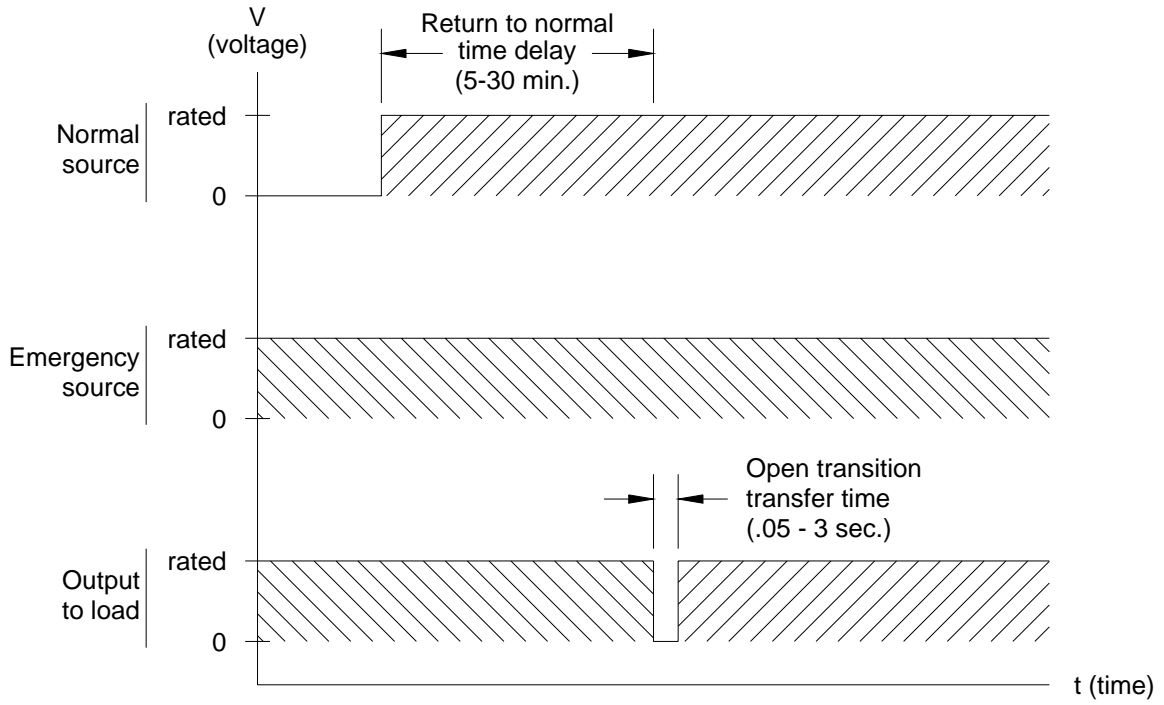

Figure 5. Contactor / Circuit Breaker ATS Re-transfer to Normal Source (open transition)

During the **closed transition transfer** from the emergency source back to the returned normal source, the emergency source will be disconnected after the normal source is connected. This will not cause an outage to the load during the transfer. Typically the duration of the connection of the two sources is less than 100 mS. Since the incoming and the running power sources connect while in synchronism, any type of load can be reliably transferred in this manner.

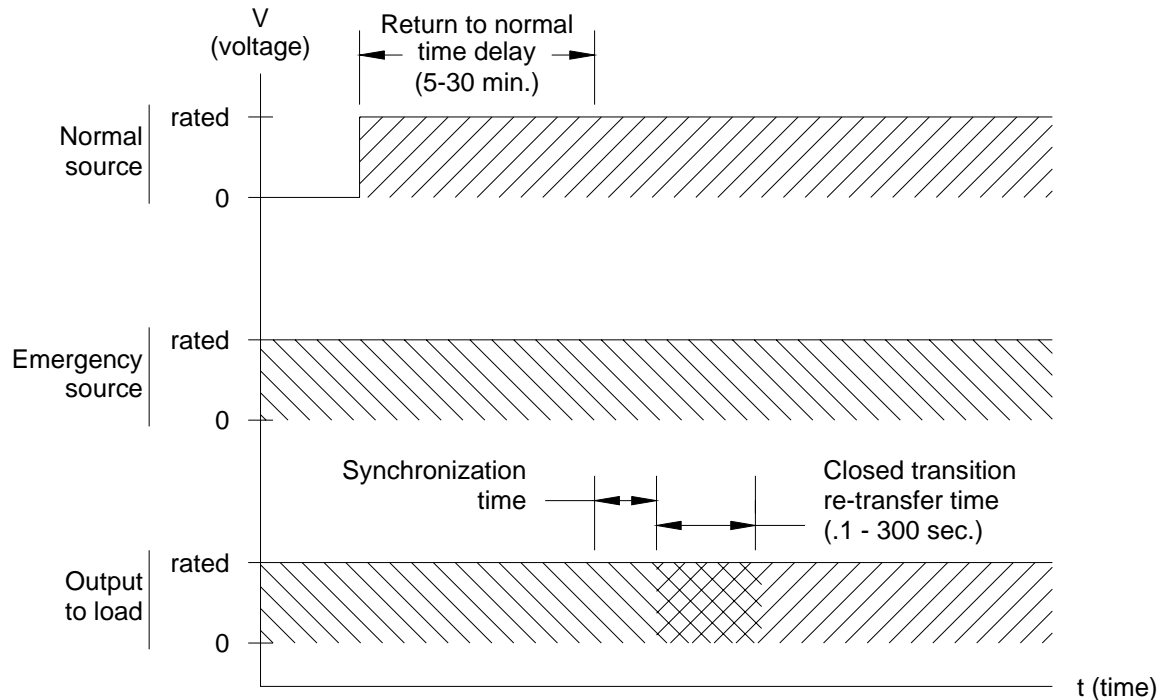

Figure 6. Contactor / Circuit Breaker ATS Re-transfer to Normal Source (closed transition)

The synchronizing of the sources for the closed transition transfer can be accomplished via **active synchronizing** and **passive synchronizing**. In both cases the paralleling of the two sources is supervised by a synchronizing check relay.

In case of passive synchronizing, the system control relies on the generator to randomly fall in to synchronism with the utility source. In case of passive synchronizing there is no way to be sure that the transfer will occur.

In case of active synchronizing, the system control monitors the voltage and frequency of both sources and provides a speed correction signal to the prime movers (engine, turbine, etc.) governing system to bring it in to synchronism with the running source (utility).

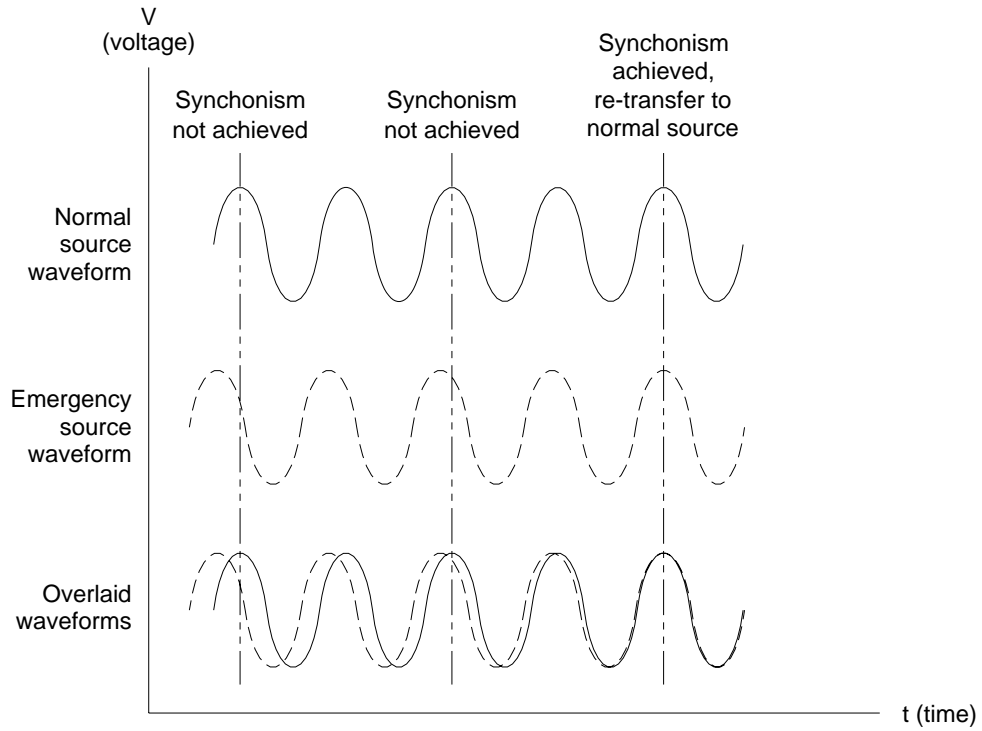

Figure 7. Synchronizing of Sources During Closed Transition
Re-transfer to Normal Source

Solid state transfer switches:

The main advantage of the solid state ATS over the contactor or circuit breaker based transfer switch is its ability to detect the failure of the normal source and transfer to the available alternate source within $\frac{1}{4}$ of a cycle. At the same time the solid state ATS are much more expensive and generally less reliable as compared to the contactor or circuit breaker based ATS. Since the emergency generator set is, typically not available for the first 10 seconds of the normal source outage, the advantages of the solid state ATS would not be utilized when used with the emergency generator set.

Solid state ATS are typically used in the systems with two constantly available separately derived and synchronized power sources, and where the nature of the load is such that brief power outage is not acceptable.

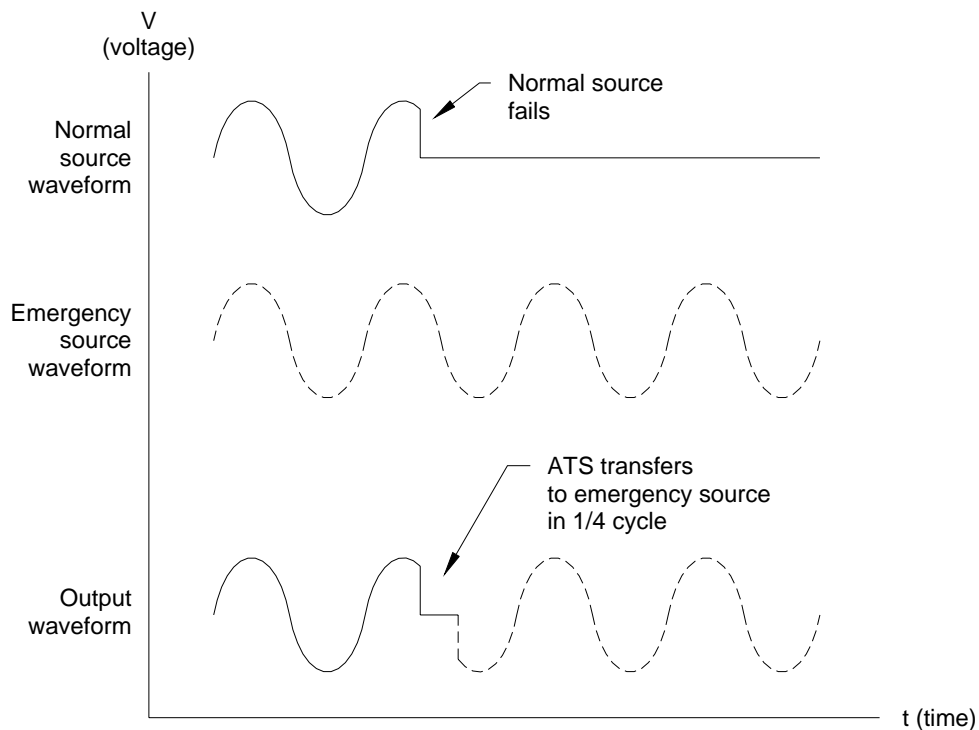

Figure 8. Solid State ATS load transfer Illustration.

Market prices.

The following table presents typical market prices, paid by the end users for ATS of different technologies:

ATS rating, Amps	Contactor based	Circuit breaker based	Solid state
200	\$1,800	\$2,700	\$29,000
400	\$3,000	\$3,700	\$36,000
600	\$4,000	\$4,000	\$38,000
800	\$6,000	\$8,000	
1200	\$12,000	\$12,000	
1600	\$14,000	\$15,000	
2000	\$15,000	\$16,000	
2500	\$24,000	\$20,000	
3000	\$26,000	\$26,000	